

Examples:

- Phosphorus pentachloride (PCl_5): P has 10 electrons in its valence shell.
- Sulfur hexafluoride (SF_6): S has 12 electrons in its valence shell.

Summary:

Feature	Period 2 Elements
Valence shell	$n = 2$
Available orbitals	2s, 2p (no d orbitals)
Maximum valence electrons	8
Expanded octet possible?	No

Conclusion:

Elements of Period 2 (like C, N, O, and F) cannot have expanded octets because:

- They lack low-energy d orbitals in their valence shell.
- They are limited to the s and p orbitals only, which hold a maximum of 8 electrons.
- Therefore, they follow the octet rule strictly, unlike elements in Period 3 and beyond.

b) Predict and explain the expanded octets in the following ions: ClO_3^- , PO_4^{3-} .

Ans. Great! Let's analyze the possibility of expanded octets in the following polyatomic ions:

- ClO_3^- (chlorate ion)
- PO_4^{3-} (phosphate ion)

We'll determine whether the central atom uses an expanded octet and why.

1. ClO_3^- (Chlorate Ion)

Step 1: Total Valence Electrons

- Cl: 7 valence electrons
- O: $3 \times 6 = 18$
- Charge: $-1 \rightarrow$ add 1 electron

Total = $7 + 18 + 1 = 26$ electrons

Step 2: Skeleton Structure

- Central atom: Cl
- 3 oxygens around Cl
- Single bonds to each O (initially)

Explanation of Expanded Octet:

If Cl only used 8 electrons (octet), it couldn't form stable structures with enough resonance but to account for resonance and formal charges, it is often shown with one double bond to one O and two single bonds to the other O. It means chlorine has 10 electrons around it is (2 double-bond electrons + 2×2 single-bond electrons = 6 bonding pairs = $12 e^-$).

So, chlorine can have an expanded octet.

Explanation of Expanded Octet:

- Chlorine is in Period 3 which has access to 3d orbitals
- Can accommodate more than 8 electrons in valence shell

Conclusion:

Cl in ClO_3^- exhibits an expanded octet to minimize formal charges and form resonance-stabilized structures.

2. PO_4^{3-} (Phosphate Ion)

Step 1: Total Valence Electrons

- P: 5 valence electrons
- O: $4 \times 6 = 24$
- Charge: $-3 \rightarrow$ add 3 electrons

Total = $5 + 24 + 3 = 32$ electrons

Step 2: Skeleton Structure

- Central atom: P
- 4 single bonds to O atoms
- Remaining electrons go on the oxygens as lone pairs

Explanation of Expanded Octet:

- In basic Lewis structures, phosphorus forms 4 single bonds to oxygen (8 bonding electrons).
- However, more resonance-stabilized forms can be drawn where one P=O double bond exists, leading to 10 electrons around phosphorus.

Yes, phosphorus can also expand its octet.

Explanation of Expanded Octet:

- Phosphorus is in Period 3
- Can utilize 3d orbitals to accommodate more than 8 electrons

Conclusion:

Phosphorus in PO_4^{3-} can have an expanded octet, especially in resonance forms with one or more P=O double bonds.

Summary:

Ion	Central Atom	Period	Expanded Octet?	Why
ClO_3^-	Cl	3	Yes	Access to 3d orbitals
PO_4^{3-}	P	3	Yes	Access to 3d orbitals

ELECTRONEGATIVITY AND THE TYPE OF BOND

> The effect of electronegativity on the type of bonding:

The difference in electronegativity of two bonded atoms provides an approximate measure of the bond polarity and an indication of the type of bond.

- When this difference is very small or zero, the bond is covalent and nonpolar.
- When it is large, the bond is polar covalent or ionic.

> Change in the nature of bond with electronegativity difference:

- The following figure graphically depicts the change in the nature of bond with electronegativity difference.
- Two atoms having electronegativity difference less than 0.4 are said to make a pure covalent bond (or non-polar covalent bond).
- An electronegativity difference between 0.4 and 1.8 corresponds to a polar covalent bond, whereas above this value the bond between two atoms will be ionic in nature.
- The electronegativity differences between the atoms in the bonds such as H-H, H-Cl, and NaCl are 0 (non-polar), 0.9 (polar covalent), and 2.1 (ionic), respectively. This is why H-H bond is purely non-polar, H-Cl a polar covalent bond, whereas NaCl is an ionic compound.

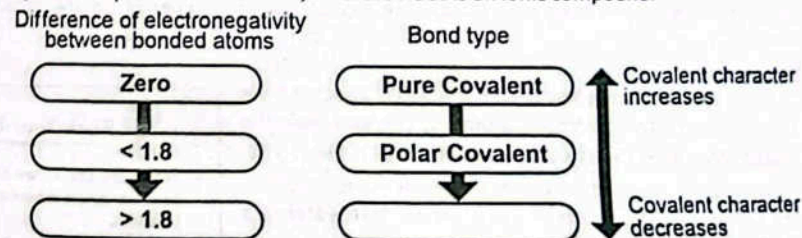

QUICK CHECK 3.3

- a) Predict with the help of electronegativity values whether the bonds in these compounds would be non-polar covalent, polar covalent, or ionic.

i) HF ii) KI iii) CaF₂ iv) ICl v) Br₂

Ans.

Compounds	Type of Bond
i) HF	Polar covalent
ii) KI	Ionic bond
iii) CaF ₂	Ionic bond
iv) ICl	Polar covalent
v) Br ₂	Non-polar covalent

Dipole Moment and Polarity of Molecules

Definition:

"The product of electric charge (q) and the distance between the positive and negative centers (r) is called dipole moment".

$$\mu = q \times r$$

Units:

The dipole moment is measured in:

- Debye (D) unit
 - Coulomb meter (Cm) – SI unit
- In compounds such as HF, where the bonded atoms are from different elements, the electronic distribution between the atoms is uneven. Due to this reason, one atom carries partial positive and the other negative charge. A molecule with δ^+ charge on one part and δ^- charge on the other part is called a dipole and such a molecule is said to have a dipole moment.
 - It is a quantitative measurement of the polarity of a bond or a molecule. The dipole moments of diatomic molecules like HF, HCl, HBr, HI, NO, etc. are directed from the positive ends (δ^+) to negative ends (δ^-) as in Fig. Higher dipole moment indicates high polarity in a molecule. Dipole moment is measured in Debye unit (D).

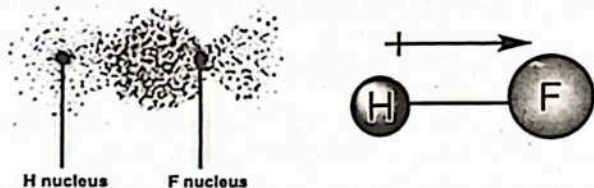

Figure: Electron density in HF is higher near the F atom and the dipole moment is directed from H to F

(a) Dipole Moment and Molecular Structure

For compounds having more than two atoms, the dipole moment depends on the structure of the molecule.

(i) Water

- The dipole moment of water is 1.85 D which is directed from the end having two hydrogen atoms to the end with the oxygen atom as in the structure shown in Fig. A linear H₂O molecule (H-O-H) would have zero dipole moment.
- The non-zero dipole moment value shows that water is a non-linear molecule.
- Experiments reveal that the water molecule has a v-shaped structure.

Rack Your Brain!

4. Which of the following molecules has zero dipole moment?
 (A) NH₃ (B) CHCl₃
 (C) H₂O (D) BF₃

(ii) SO₂

- SO₂ has a dipole moment of 1.61 D and in opposite direction to that in water.

(iii) H₂S

- H₂S is also a non-linear molecule as the individual bonds are polar, but they don't cancel each other's dipole moment and the overall molecule has some dipole moment.

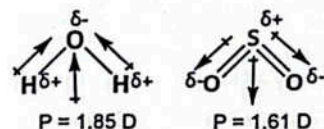

Electron density map of the water molecule. Red represents the rich oxygen region, and blue represents the electron-deficient hydrogen end. Dipole moment is from blue to red

Figure: Vector addition of individual bond moments in angular H₂O and SO₂ molecules

(b) Zero Net Dipole Moment

Some molecules have zero dipole moments as the symmetry in their structures causes the cancellation of the individual bond moments.

(i) BeCl₂

- BeCl₂ is a linear molecule having two similar Cl atoms on both sides of the central atom at 180°. The individual Be-Cl bond moments are cancelled out as they are opposite in direction and equal in amount.

(ii) CCl₄

- CCl₄ has four C-Cl bonds which are expected to have high polarity due to a large electronegativity difference between C and Cl atoms. The bond moments associated to the four C-Cl bonds are directed in such a way that they cancel each other. The net dipole moment of the CCl₄ molecule is zero making it a non-polar molecule. The CCl₄ molecule is perfectly tetrahedral.

(iii) BF₃

- BF₃ has a trigonal planar symmetrical structure and its dipole moment is also zero. As a rule, the molecules that have same ligands (atoms or groups of atoms with the central atom) in a regular geometry, the individual dipole moments may not be zero, but overall molecule has zero dipole moment. Such a molecule is said to be non-polar.

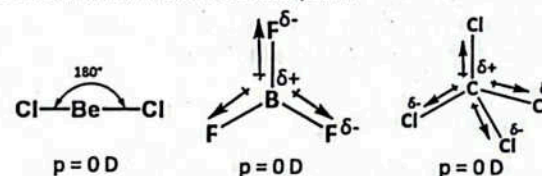

Figure: The individual bond moments in symmetrical molecules; BeCl₂, BF₃ and CCl₄ are cancelled out to give zero net dipole moment.

QUICK CHECK 3.4

- a) Can you explain why CO has a dipole moment but CO₂ does not have any?

Ans. CO has a dipole moment while CO₂ does not have any.

Reason: CO₂ has a linear structure, because the dipoles being equal and opposite, cancel out each other's effect. Similarly CS₂ has zero dipole moment.

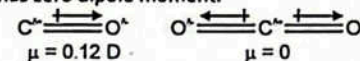

- b) Do you think that individual bonds CCl₄ are polar? Explain in terms of the electronegativity difference. What about the polarity of overall CCl₄ molecule?

Ans. Electronegativity of C = 2.5

Electronegativity of Cl = 3.2

Individual C-Cl bonds in CCl₄ are polar due to electronegativity difference with partial positive charge on C and partial negative charge on Cl. So each C-Cl bond is polar with a dipole moment.

However, due to symmetrical tetrahedral shape of CCl₄, the overall molecule is non-polar because the individual bond dipoles cancel each other.

c) Are these molecules polar or non-polar? Briefly give reasons. HF, CH₂Cl₂, O₂, H₂S

Molecules	Dipole moment	Polar/Non-polar
HF	1.83 D	Polar
CH ₂ Cl ₂	1.60 D	Polar
O ₂	0.0 D	Non-polar
H ₂ S	0.97 D	Polar

INTERMOLECULAR FORCES

Intermolecular forces are also the binding forces just like chemical bonds. However, the attraction between the molecules is much weaker than the chemical bonds. These forces are believed to exist between all kinds of atoms and molecules when they are sufficiently close to each other. Such intermolecular forces are called van der Waals forces. These intermolecular forces bring the molecules close together and give particular physical properties to the substances in gaseous, liquid, and solid states.

Three types of such forces are mentioned here:

- Instantaneous dipole-induced dipole forces or London dispersion forces.
- Permanent dipole-permanent dipole forces
- Hydrogen Bonding
(For the detailed discussion on these forces, see the chapter "states and phases of matter").

BOND ENERGY AND BOND LENGTH

"The bond energy is the average amount of energy required to break all bonds of a particular type in one mole of a substance."

- It is determined experimentally by measuring the heat involved in a chemical reaction and its unit is kJ mol⁻¹.
- Bond energy is a measure of the strength of a bond and its reactivity.
- The strength of a bond depends upon the following factors.

> Factors Affecting Bond Energy:

- Electronegativity difference of bonded atoms
- Size of atoms.

The bond energies/enthalpies of some bonds are presented in Table.

Table: Average bond energies of some selected bonds in kJ mol⁻¹

Single bonds				Multiple bonds			
H-H	432	C-I	240	F-F	154	C=C	614
H-F	565	C-Cl	339	Cl-Cl	239	C≡C	839
H-Cl	427	C-N	305	Br-Br	193	O=O	495
H-Br	363	C-O	358	I-I	149	C=O	745
H-I	295	N-H	391	S-S	266	N≡N	941
C-H	413	N-O	201	Si-Si	340	C≡N	615
C-C	347	O-H	467	Si-O	452	N=O	607

Let us consider the role played by electronegativity difference. Look at the bond energies of H-X type of compounds, where X=F, Cl, Br, I. The data show that the bond energy of a bond rises with the increasing electronegativity difference between the bonded atoms. As the difference in electronegativity increases, the bond polarity also becomes greater and this gives rise to additional attractive force for binding the atoms.

This is why the bond energy for HF is higher (565 kJ mol⁻¹) than for HI (295 kJ mol⁻¹). It may be noted that energies of multiple bonds are greater than those of single bonds.



> Bond Length:

- Definition:** "Bond length is the distance between the nuclei of two atoms forming a covalent bond".
- Measurement:** The bond lengths are experimentally determined by physical techniques, such as electron diffraction, X-ray diffraction, or spectral studies.
- Factors Affecting Bond Length:** The bond length of a bond is governed by many factors including electronegativity (electronegativity difference), size, and the nature of the covalent bond (single, double, or triple).
- Explanation:** With an increase in size of the atoms, the covalent bond length also increases. The C-Cl bond length is about 180 pm, whereas the C-F bond length is 135. This is because the Cl atom is much larger. With the rise in electronegativity difference between the bonded atoms, the bond becomes shortened. For example, Si-F bond length in SiF₄ is found to be near 155 pm, whereas the calculation of Si-F bond from the covalent radii of Si and F (Si=117pm and F=64pm) is 181 pm. The electronegativity difference causes an ionic character in the covalent bond. The ionic character results in shortening of the bond length due to the additional attraction between the bonded atoms.
- Some selected bond lengths are given in Table.

Table: Bond lengths of some selected bonds

Bond	Bond length (pm)	Bond	Bond length (pm)
H-H	74	Si-F	155
H-Br	144	C-F	135
C-C	154	C-Cl	180
C=C	133	C-Br	196
C≡C	120	C-I	214
C=O	122	B-F	130
Si-H	146	B-Cl	175

QUICK CHECK 3.5

- (a) HI is a stronger acid and a robust reducing agent, whereas HF is a weaker acid. Explain.
Ans. The difference in acid strength and reducing ability between HI (hydroiodic acid) and HF (hydrofluoric acid) is rooted in bond strength, electronegativity, and ion stability.

Reasons:

1. Acid Strength: HI > HF

Acid strength depends on how easily a molecule donates a proton (H⁺).

Bond strength (H-X bond):

- H-F bond is very strong (565 kJ/mol) due to the small size of fluorine and strong overlap with hydrogen.
- H-I bond is much weaker (297 kJ/mol) because iodine is large and the overlap with hydrogen's orbital is poor.

Weaker H-I bond breaks more easily, releasing H⁺ more readily → stronger acid.

Anion stability (F⁻ and I⁻):

- F⁻ is small and highly charged (high charge density) → strongly attracts protons, so it holds onto H⁺ tightly → reverses the dissociation.
- I⁻ is large, more polarizable, and better stabilizes the negative charge → doesn't recombine as easily with H⁺ → acid remains dissociated.

I⁻ is more stable in solution than F⁻ → favors complete dissociation → stronger acid.

2. Reducing Strength: HI > HF

A reducing agent donates electrons (i.e., gets oxidized itself).

- In redox terms:

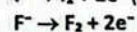
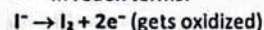

Ease of oxidation:

- I^- is much easier to oxidize than F^- because:
 - Iodine has a lower electronegativity (2.5) than fluorine (4.0)
 - Fluoride ion (F^-) is very stable and resists giving up electrons
 - I^- can be oxidized to I_2 more readily \rightarrow good reducing agent

HI is a stronger reducing agent because I^- is more easily oxidized than F^- .

Property	HI	HF
H-X Bond Strength	Weak (easily broken)	Strong (hard to break)
Acid Strength	Strong acid	Weak acid
X^- Anion Stability	I^- stable (large, polarizable)	F^- less stable (small, high charge density)
Reducing Power	Strong reducing agent	Weak reducing agent

(b) Acetylene ($HC \equiv CH$) is more stable than ethene ($H_2C = CH_2$). Can you explain why?

Ans. Actually, acetylene (C_2H_2) is less stable than ethene (C_2H_4) in terms of enthalpy or thermodynamic stability — not more stable.

Explanation:

Structures

• Acetylene (C_2H_2):

Linear molecule with a triple bond between the carbon atoms: $H-C \equiv C-H$

• Ethene (C_2H_4): Planar molecule with a double bond between the carbon atoms: $H_2C = CH_2$

Thermodynamic Stability (Bond Energies)

Let's look at the total bond energy (approximate values):

Molecule	C-C Bond Type	C-H Bonds	Total Bond Energy (kJ/mol)
Acetylene	1 triple (839 kJ/mol)	$2 \times C-H (2 \times 412) = 824$	1663
Ethene	1 double (614 kJ/mol)	$4 \times C-H (4 \times 412) = 1648$	2262

Ethene has more total bond energy \rightarrow more stable (lower energy).

Higher total bond energy = more stable molecule

Heat of Formation (ΔH_f°)

- Acetylene (C_2H_2): +226 kJ/mol (positive \rightarrow less stable)
- Ethene (C_2H_4): +52 kJ/mol (less positive \rightarrow more stable)

Ethene has a lower heat of formation \rightarrow more thermodynamically stable.

Acetylene can seem "stronger" or "tougher" because of the triple bond, which is short and strong. But this doesn't mean it's more thermodynamically stable overall. In fact, acetylene contains more energy (more reactive), which is why it's used as a fuel (e.g. in oxy-acetylene torches).

Property	Acetylene (C_2H_2)	Ethene (C_2H_4)
C-C Bond Type	Triple	Double
Heat of Formation (ΔH_f°)	+226 kJ/mol	+52 kJ/mol
Thermodynamic Stability	Lower	Higher
Reactivity	Higher (more reactive)	Lower

A COMPARISON AMONG IONIC, COVALENT, METALLIC BONDS AND INTERMOLECULAR FORCES

Chemical bonds (ionic, covalent, and metallic bond) are usually termed as true chemical bonds because they affect the chemical properties of a substance.

Distinction between chemical bonds and intermolecular forces:

- (i) Chemical bonds result in the formation of new species through transfer and sharing of electrons. Whereas, intermolecular forces act to bring molecules closer and influence the physical properties. (However, such a clear distinction between the chemical bonds and intermolecular forces is not possible).

- (ii) Bond Strength: The distinctive feature of the chemical bonds and intermolecular forces is their bond strength. The strength of a force is measured by the bond energy. Table provides a comparison among different chemical bonds and intermolecular forces.

Table: Relative strengths of chemical bonds and intermolecular forces

Bond Type	Bond Energy (kJ mol ⁻¹)
Ionic bond in NaCl	760
O-H bond in water	464
Hydrogen bonding	20-50
Permanent dipole-Permanent dipole force	5-20
Van der Waals forces	1-20

The bond energy of ionic bond (sodium chloride, 760 kJ mol⁻¹) is highest, followed by covalent bond (O-H = 464 kJ mol⁻¹) and average hydrogen bond energy (20-25 kJ mol⁻¹). It shows that the ionic bond is the strongest form of chemical bonding. It also reveals that chemical bonds are generally much stronger than intermolecular forces. The permanent dipole-dipole forces (5-20 kJ mol⁻¹) and London dispersion forces (1-20 kJ mol⁻¹) are even weaker as indicated by their low bond energies.

The metallic bond is mostly elaborated in terms of electrostatic forces, although some theories suggest that it may be of covalent nature. In any case, the metallic bond is weaker than both the ionic and covalent bonds. The average bond energy of the metallic bond is 100-150 kJ mol⁻¹. A satisfactory argument for the low strength of metallic bond is extensive delocalization of electrons within the metallic crystal.

VALENCE BOND THEORY (VBT)

(Exercise L.O.3)

- Q. How the bonding in the following molecules can be explained with respect to valence bond theory?

(i) Cl_2 (ii) O_2 (iii) N_2 (iv) HF (v) H_2S

The VSEPR model predicts and explains the shapes of molecules but does not give reasons for the formation of bonds.

➤ Introduction of VBT:

VBT is concerned with both the formation of bonds and the shapes of molecules. This method of describing a covalent bond considers a molecule as a combination of atoms

➤ Postulates of VBT:

The postulates of VBT are given below:

- A covalent bond is formed when half-filled orbitals in the valence shells of two atoms with similar energy overlap.
- A greater overlap of the orbitals results in a stronger bond.
- Covalent bonds are directional. The direction of the bond is determined by the shape and mode of the overlapping orbitals.

➤ Formation of Sigma Bond

A sigma bond is formed by the linear overlap of two half-filled atomic orbitals on adjacent atoms. The orbitals approach each other on the nuclear axis. Both s and p orbitals can overlap head-on to form sigma bonds.

➤ s-s Overlap (H-H Molecule)

The 's' orbital of one atom overlaps with the s-orbital of the other to give a bond orbital. This type of overlap occurs during the formation of the H_2 molecule, where each hydrogen atom has a half-filled 's' orbital. After the bond formation, the electrons are paired up and the electron density in this molecule is symmetrical around the two nuclei as in Figure.

 Rack Your Brain!

5. How sigma bonds are formed?

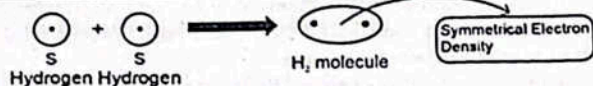

Figure: Overlap between s orbitals of two hydrogen atoms to form the H₂ molecule

s-p Overlap (H-Cl Molecule)

The s orbital of one atom can overlap with the p orbital of the other to form a covalent bond (σ). For example, in HCl molecule, a half-filled s orbital of hydrogen overlaps with a half-filled p orbital of chlorine as shown in Figure. The electron density is higher close to the Cl atom due to its higher electronegativity value. This is why HCl is a polar molecule.

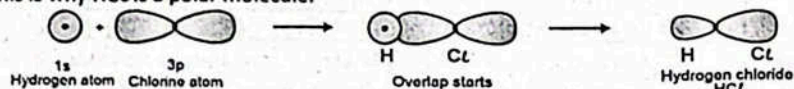

Fig.: Formation of σ bond by s-p overlap

p-p Overlap (Cl-Cl Molecule)

An example of this type of overlap is the formation of the Cl₂ molecule where 'p' orbitals of two chlorine atoms overlap on the nuclear axis. The electron density is symmetrical around the nuclei of the two Cl atoms because both have same value of electronegativity.



Figure: Overlap of p and p orbitals to form Cl₂ molecule according to VBT

Interesting Information!

The bond angle in H₂O is 104.5°, whereas in H₂S, it is 92°. This is because the orbitals of S are larger and the lone pair exerts a stronger repulsion.

Rack Your Brain!

6. How pi (π) bonds are formed?

H₂S Molecule

The H₂S molecule is a non-linear molecule which is formed by the combination of one Sulphur and two hydrogen atoms. The two 3p (say 3p_y and 3p_z) orbitals of Sulphur containing one electron each can overlap with the 1s orbitals of two hydrogen atoms. A v-shaped molecule is thus formed having a bond angle of 92° as in Fig.

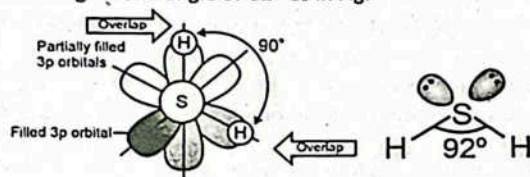

Fig.: The formation of H₂S molecule by H and S orbitals overlap

Formation of π bond

Formation of Double bond in O = O

Consider the formation of a double covalent bond between oxygen atoms (O = O). There are two unpaired electrons on each atom in perpendicular p orbitals (say P_x and P_y). The p_x orbitals on the two oxygen atoms are oriented in such a way that they overlap end-to-end linearly. The linear overlap of the p_x orbitals gives a σ bond. However, the p_y orbitals on both atoms are aligned parallel to each other. They overlap in a parallel way so that the two p lobes overlap above the plane of the nuclei and the other two lobes below the plane as shown in Figure. This results in the formation of π bond. The oxygen atoms are doubly bonded through σ and π bonds.

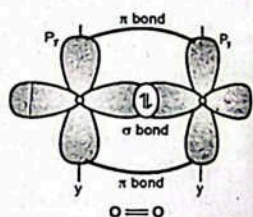

Figure: Formation of double bond (σ and π) between oxygen atoms

QUICK CHECK 3.6

a) Draw the orbital structures of H₂O and N₂ molecules.

Ans. Water (H₂O)

Lewis Structure:

- Oxygen (O): 6 valence electrons
- Hydrogen (H): 1 each $\times 2 = 2$
- Total = 8 electrons
- Oxygen forms 2 single bonds with hydrogen and retains 2 lone pairs

Electron Geometry:

- 4 electron regions (2 bonding pairs + 2 lone pairs)
- Electron geometry: Tetrahedral
- Molecular shape: Bent (V-shaped) due to lone pair repulsion
- Bond angle: 104.5°

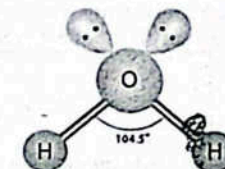

2. Nitrogen Molecule (N₂)

Lewis Structure:

- Each nitrogen atom has 5 valence electrons
- They share three pairs of electrons to form a triple bond
- Each N has a lone pair remaining

Electron Geometry:

- Only 2 atoms, so it is linear
- Bond type: Triple bond
- Molecular shape: Linear
- Bond angle: 180°

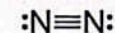

b) Draw the orbital overlap to show the formation of F₂ and HF molecules.

Ans. Fluorine molecule (F₂)

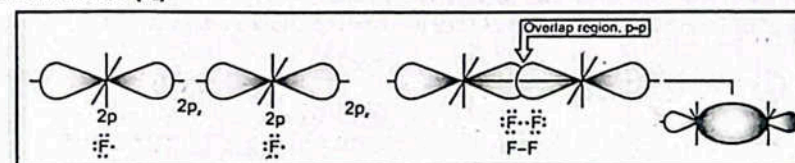

The formation of the fluorine molecule

Hydrogen Fluoride Molecule (HF)

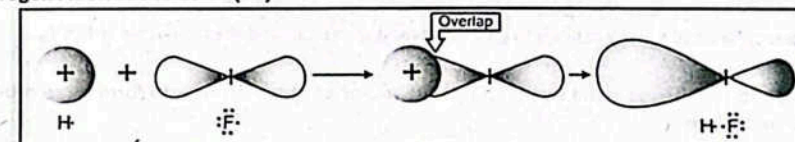

The formation of the hydrogen fluoride molecule

ATOMIC ORBITAL HYBRIDIZATION

(Exercise 1.0)

Q. Explain the orbital hybridization for CH_4 , NH_3 , BF_3 , and BeCl_2 .

Hybridization:

A process in which atomic orbitals of slightly different energies and shapes are mixed together to form a new set of equivalent orbitals of same energy and same shape is called hybridization.

KEEP IN MIND

- Hybridization is a process of mixing of orbitals in a single atom (or ion).
- Only orbitals of comparable (relatively close) energies can be mixed to form hybrid orbitals.
- The number of mixing orbitals is always equal to the number of the resulting hybrid orbitals.

Types of Hybridization

sp Hybridization

- In sp hybridization, one s (low energy and spherical) and one p (high energy and dumb-bell shaped), intermix to give a new set of two orbitals of same energy and same shape called sp hybrid orbitals. These sp hybrid orbitals are arranged in linear geometry and oriented at 180° .
- Beryllium Chloride (BeCl_2): The electronic configuration of the outermost shell of Be is as follows:

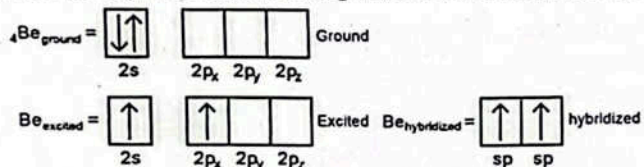

- The two sp hybrid orbitals lie linearly as in the following diagram Fig. The sp hybridization explains the geometry of linear molecules such as beryllium chloride, BeCl_2 . It is formed when two sp hybrid orbitals of Be atom overlap with the half-filled p-orbitals of chlorine atoms.

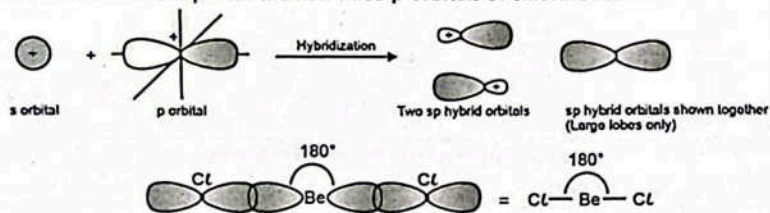

Figure: Mixing of s and p orbitals to give two hybrid sp orbitals and the formation of BeCl_2

sp² Hybridization

- In sp² hybridization, one s and two p atomic orbitals of an atom intermix to form three orbitals called sp² hybrid orbitals.
- The three half-filled sp² hybrid orbitals are arranged in a trigonal planar geometry with bond angles of 120° .

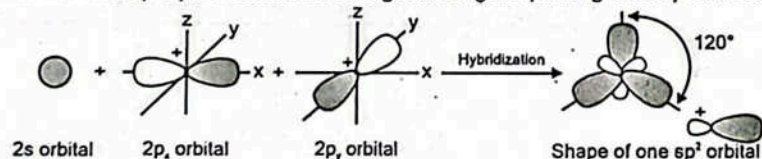
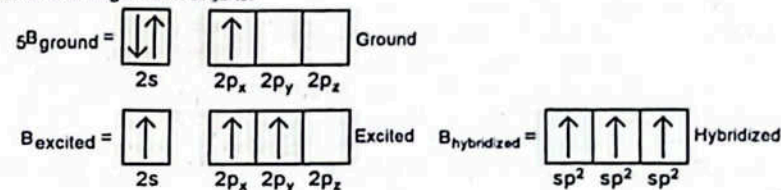

Figure: Formation of sp² hybrid orbitals from atomic orbitals

- Boron Trifluoride (BF_3): The sp² hybridization explains the geometry of planar molecules such as BF_3 . Electronic configuration of ${}_5\text{B}$ is:



- The three outermost orbitals of B mix together to give three sp² hybrid orbitals. On the other hand, one of the p orbitals of fluorine is half filled (e.g. 2p_z). BF_3 is formed by the overlap of three half-filled sp² hybrid orbitals of boron with 2p_z orbitals of three fluorine atoms. The structure is trigonal planar with bond angles equal to 120° , each as in Figure.

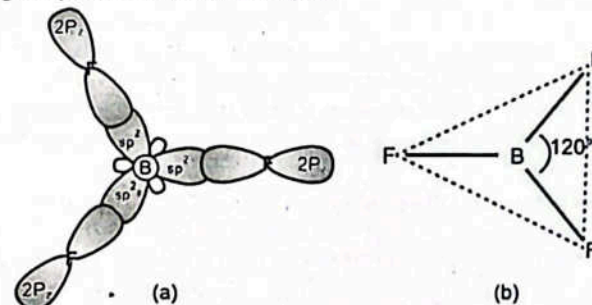
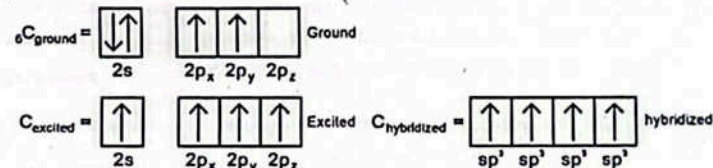

Figure: Formation of BF_3 molecule through sp²-p overlap

sp³ Hybridization

- In sp³ hybridization, one s-orbital (low energy and spherical) and three p-orbitals (high energy and dumbbell shaped), intermix to give a new set of four orbitals of same energy and same shape. Each of these hybrid orbitals is a sp³ hybrid orbital.
- Methane (CH_4): These hybrid orbitals are arranged in the tetrahedral geometry as shown in the example of CH_4 as in Fig.
- The electronic configurations of valence shell of ${}_6\text{C}$ in its excited and hybridized states are given as follows:



- The energies of hybrid orbitals are lower than unhybrid orbitals. Figure shows the outermost four atomic orbitals of carbon mix up to give four hybrid orbitals of same energy and same shape.

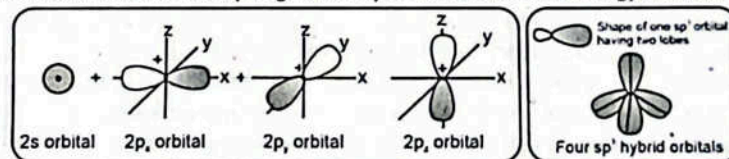

Figure: Formation of sp³ hybrid orbitals of C in methane

- The four new hybrid orbitals of equal energy have a tetrahedral geometry with carbon nucleus at the center. The methane molecule is formed by the overlap of sp^3 hybrid orbitals of carbon with $1s$ orbitals of four hydrogen atoms separately to form four sigma bonds. The four C-H bonds, which result from sp^3 - s overlaps, are directed towards the corners of a regular tetrahedron.

Did You Know?

Each sp^3 hybrid orbital consists of two lobes, one larger and the other smaller. For the sake of simplicity, the smaller lobe is usually not shown while representing sp^3 hybrid orbitals together.

VALENCE SHELL ELECTRON PAIR REPULSION MODEL (VSEPR)

Exercise 10.4

Q. What are the postulates of VSEPR model? Discuss the structures of the following species with reference to this theory.

- (i) CH_4 (ii) NH_3 (iii) H_3O^+ (iv) PCl_5 (v) SO_2 (vi) SF_6

The VSEPR model describes the shapes of molecules based on the electron pairs that surround the central atom. This model was presented by Sidgwick and Powell in 1940. It is based on the assumption that a molecule will take a shape such that the electronic repulsions among the valence electrons of that atom are minimum. In order to have the minimal repulsions, the electron pairs arrange themselves at farthest possible distances. This arrangement of the electron pairs determines the geometry of the resulting molecule.

Postulates:

- Both the lone pairs (non-bonded) as well as the bond pairs participate in determining the geometries of molecules.
- The electron pairs are arranged around the central atom so as to remain at maximum distance apart to avoid repulsions.
- The electrons of lone pairs occupy more space than the bond pairs. As a result, the non-bonding electron pairs exert greater repulsive forces on bonding electron pairs and, thus, tend to compress the bond pairs. The magnitude of repulsions between the electron pairs in a given molecule decreases in the following order:

Lone pair-lone pair (lp-lp) > lone pair-bond pair (lp-bp) > bond pair (bp-bp)



An electron pair shared by two nuclei occupies less space than a lone pair bound by a single nucleus

- The two electron pairs of a double bond and three electron pairs of a triple bond, contain a higher electronic charge density, but they are regarded as single pairs.
- The presence of highly electronegative atoms with the central atom results in decreased electronic repulsions between the bond pairs, but stronger repulsion by the lone pair.

Rack Your Brain!

7. Why does lone pair of electrons occupy more space as compared to bond pair?

Predicting the Shapes of Molecules

In order to illustrate this model, the central atom is named 'A'. The electron pairs around 'A' are designated as 'B'. There may be different number of electron pairs around the central atom depending upon its valency. It gives rise to various types of molecules, such as AB_2 , AB_3 , AB_4 , etc. The electron pair geometry of a molecule is determined by the total number of electron pairs around 'A' whereas, the actual shape of the molecule is determined by the atoms excluding the lone pairs. Following Table gives the possible shapes of different types of molecules having varying numbers of bond and lone pairs.

Table: Geometries and shapes of different systems of covalently bonded compounds

No. of electron pairs around central atom	No. of lone pairs	Electron pair geometry	Shape with respect to atoms	Angular separation of atoms	Examples
2	0	linear	linear	180°	CO_2 , $BeCl_2$
3	0	trigonal	trigonal	120°	BCl_3 , SO_3
3	1	trigonal	Angular, v-shaped	Less than 120°	SO_2 , $SnCl_2$
4	0	tetrahedral	tetrahedral	109.5°	CH_4 , CCl_4
4	1	tetrahedral	pyramidal	Less than 109.5°	NH_3 , H_3O^+
4	2	tetrahedral	Angular, v-shaped	Less than 109.5°	H_2O , OF_2
5	0	Trigonal	Trigonal bipyramidal	$120^\circ, 90^\circ$	PCl_5 , I_3^-
6	0	octahedral	octahedral	90°	SF_6 , XeF_4

Steps to Determine the Shapes of Molecules

The following steps are followed to predict the shape of a molecule.

- The least electronegative atom or the element with the least number of atoms is mostly selected as the central atom. For example, in CCL_4 , the carbon atom is the central atom.
- The total number of electron pairs around the central atom are counted (including bond pairs and lone pairs). For example in CCL_4 , the total number of bond pairs around the C atom are 4 and it has no lone pair.
- The total number of electron pairs determines the electron pair geometry (as in the above table) of the molecule. For example, CCL_4 has total four electron pairs and its geometry is tetrahedral.
- Finally, the actual shape of the molecule is determined excluding the lone pairs (if any).

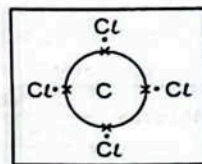

KEEP IN MIND

Number of electron pairs around the central atom are calculated as in the following example:

- Valence electrons in $N = 5$
- Electrons shared by $3H = 3 \times 1 = 3$
- Total number of electrons = $5 + 3 = 8$
- Total number of electron pairs = $\frac{8}{2} = 4$

Calculation for lone pairs on N
No. of lone pairs on $N = \text{Total no. of pairs} - \text{no. of bond pairs}$
No. of lone pairs on $N = 4 - 3 = 1$
Thus, N has 1 lone pair in NH_3

AB_2 type Molecules (Linear geometry)

In such molecules, two electron pairs around the central atom are arranged at an angle of 180° to minimize repulsions between them. Thus, they form a linear geometry as shown in Figure. $BeCl_2$ molecule is of AB_2 type with Be as the central atom and two bond pairs around it, but no lone pair.

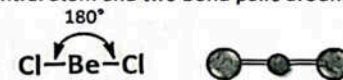

Figure: Linear shape of the $BeCl_2$ molecule

Molecule	Electron pairs			Type	Arrangement of pairs	Molecular geometry	Shape
	Total	Bonding	Lone				
$BeCl_2$	2	2	0	AB_2	Linear	Linear	$Cl-Be-Cl$ 180°
$MgCl_2$	2	2	0	AB_2	Linear	Linear	$Cl-Mg-Cl$ 180°

Other Examples: $MgCl_2$, $CaCl_2$, $CdCl_2$, $SrCl_2$, $HgCl_2$

AB₃ type (Trigonal planar geometry)

AB₃ type with bond pairs and no lone pair:

In AB₃ type molecules, the central atom is surrounded by three electron pairs, which are arranged at maximum distance apart at an angle of 120° giving a trigonal geometry.

Example BF₃ Molecule: BF₃ molecule has a trigonal planar shape with each F-B-F bond angle of 120° Figure. The similar geometries are expected in the hydrides of group 3 (III-A), i.e. AlH₃, GaH₃, BH₃, etc.

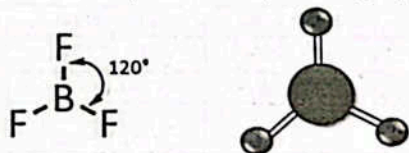

Figure: BF₃ is an AB₃ system having triangular planar geometry

AB₃ type with one lone pair and two bond pairs:

In SnCl₂, the Sn atom has 4 electrons in its outermost shell. It makes two bonds with two Cl atoms and the remaining two electrons exist as a lone pair (Figure below). One of the corners of the triangle is occupied by this lone pair, giving rise to a distorted trigonal electron pair geometry (in vapour phase). The actual shape of SnCl₂ is v-shaped and bond angle less than 120° due to the presence of a lone pair on Sn atom.

Molecule	Electron pairs			Type	Arrangement	Geometry	Shape
	Total	B	L				
SnCl ₂ [Stannous chloride]	3	2	1	AB ₃	Triangular planar	Bent or angular	

AB₃ Type with Multiple Bonds

The molecule of SO₃ has all the three regions occupied by S = O bonds. The structure of SO₃ is perfectly trigonal with each angle equal to 120°. On the other hand, in SO₂, one corner of the triangle is occupied by a lone pair and the other two corners each by a double bond (S = O). Thus, it makes an angular or v-shaped structure just as SnCl₂ does as in Fig.

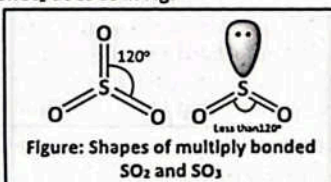

Rack Your Brain!

8. Geometry of SO₂ molecule is:
 (A) Linear (B) Angular
 (C) Tetrahedral (D) Trigonal pyramidal

Molecule	Electron pairs			Type	Arrangement	Geometry	Shape
	Total	B	L				
SO ₂ [Sulphur dioxide]	3	2	1	AB ₃ with multiple bonds	Triangular planar	Bent or angular	
Molecule	Electron pairs			Type	Arrangement	Geometry	Shape
	Total	B	L				
SO ₃ [Sulphur trioxide]	3	3	0	AB ₃ with multiple bond	Triangular planar	Triangular planar	

AB₄ Type (Tetrahedral geometry)

AB₄ type with four bond pairs and no lone pair:

In this type of molecules, the charge clouds due to four electron pairs avoid their electrostatic repulsions by being farthest apart to form the shape of a regular tetrahedron. Each of the bond angles is of 109.5°. Each of the four valence electrons of carbon pair up with the sole (one) electron of a hydrogen atom in methane. The four bonded electron pairs are directed from the center towards the corners of a regular tetrahedron, (as shown in Fig) with each corner representing a hydrogen nucleus. This arrangement permits a non-planar geometry of electron pairs. Each H-C-H bond angle is perfectly 109.5°.

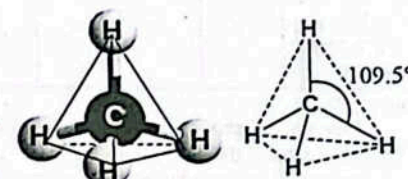

Figure: Regular tetrahedral shape of the CH₄ molecule

Examples: On the same grounds, SiH₄, GeH₄, CCl₄ possess the similar shape.

Molecule	Electron pairs			Type	Arrangement of pairs	Geometry	Shape
	T	B	L				
CH ₄	4	4	0	AB ₄	Tetrahedral	Tetrahedral	

Extend Your Knowledge

The tetrahedral shape has four corners, four faces, six edges and six bond angles. Ideally it has bond angles of 109.5° each.

AB₄ type with three bond pairs and one lone pair:

(i) NH₃

- In the ammonia molecule (NH₃), there are three atoms attached to the nitrogen atom having one lone pair.
- Due to a lone pair, the ideal angle 109.5° is reduced to 107° as in Figure. This effect compels ammonia to assume a triangular pyramidal shape with reduced bond angles, instead of a tetrahedron.
- The substitution of hydrogen in NH₃ with electronegative atoms like F or Cl further reduces the bond angles.

(ii) NF₃

- Take the example of NH₃, which contains three highly electronegative F atoms bonded to the N atom. The bond angles are further compressed to 102.5°.

Reasons:

The first reason being the strong polarity of N-F bond, due to which N atom pulls the lone pair closer to its nucleus. This, in turn, exerts a stronger repulsion over bonding electrons. Moreover, the bond pairs (N-F bonds) are closer to F atoms than N atom. The increased distances in these bond pairs make their repulsions weaker and allow the bonds to come closer.

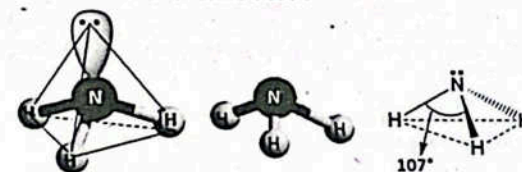
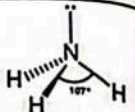
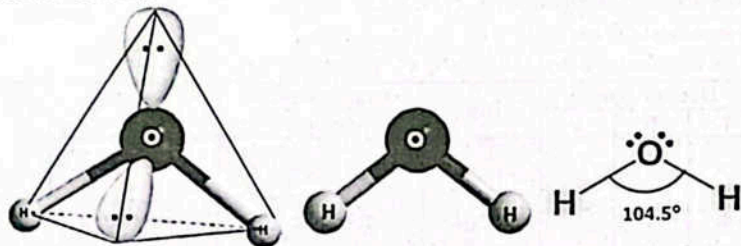

Figure: Distorted geometry and pyramidal shape of the NH₃ molecule

Molecules	Electron pairs			Type	Arrangement of pairs	Geometry	Shape
	Total	B	L				
NH ₃ Ammonia	4	3	1	AB ₃	Tetrahedral	Trigonal Pyramidal	

(iii) H₂O

Experiments show that the water molecule (H₂O) is angular or v-shaped, although it has four electron pairs around the central atom. Two of the corners of the tetrahedron are occupied by two lone pairs and the remaining two by bond pairs. But, due to the greater repulsions of the lone pairs, the bond angle is reduced to 104.5° as in Fig.



Tetrahedral geometry including lone pairs Angular shape of water molecule excluding lone pairs

Figure: Water molecule has two lone pairs and is v-shaped with suppressed bond angle

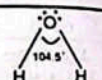
Molecule	Electron pairs			Type	Arrangement of pairs	Geometry	Shape
	Total	B	L				
H ₂ O	4	2	2	AB ₂	Tetrahedral	Bent or angular	

(iv) Hydronium Ion

The VSEPR model also explains the shapes of ions. The hydronium ion [H₃O]⁺ is formed when a water molecule captures a proton. The hydronium ion belongs to AB₃ type with one lone pair and possesses trigonal pyramidal shape just like the ammonia molecule.

(v) Amide Ion

The amide ion [NH₂]⁻ is also AB₂ type as it is surrounded by two lone pairs and two bond pairs. Its geometry is tetrahedral, but it has a bent shape (v-shape) similar to the water molecule (Figure).

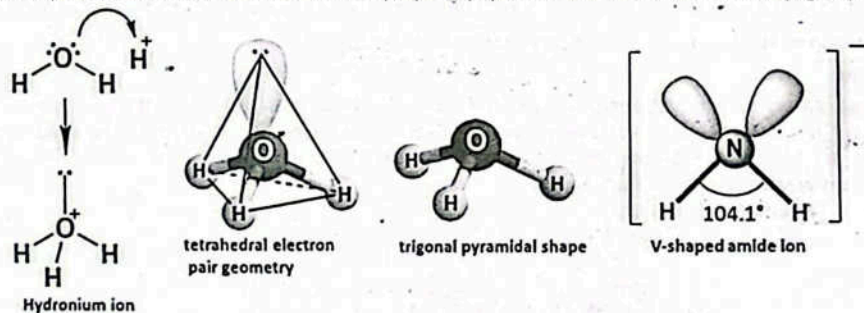

Figure: Shapes of hydronium (H₃O⁺) and amide ions (NH₂⁻)

 QUICK CHECK 3.7

a) Calculate the number of lone pairs on the central atoms in the following: H₂O, ICl₃, I₃⁻

Ans. H₂O (Water):

- Central atom: Oxygen (O)
- Valence electrons of O: 6
- Hydrogen atoms: 2 × 1 = 2 electrons shared
- Total electron pairs around O: (6 + 2)/2 = 4 pairs
- Bonding pairs: 2 (from two O – H bonds)
- Lone pairs on O: 4 – 2 = 2 lone pairs

ICl₃ (Iodine Trichloride)

- Central atom: Iodine (I)
- Valence electrons of I: 7
- Chlorine atoms: 3 × 1 bond = 3 bonding pairs
- Total valence electrons involved: 7(I) + 3 (shared with Cl) = 10 electrons = 5 pairs
- Bonding pairs: 3
- Lone pairs on I: 5 – 3 = 2 lone pairs

I₃⁻ (Triiodide ion)

- Central atom: Iodine (middle I)
- Total Valence electrons:
 - 3 Iodine atoms = 3 × 7 = 21
 - Extra 1 electron (due to -1 charge) = 22 electrons
- Total electron pairs: 22 ÷ 2 = 11 pairs
- Bonding pairs: 2 (I – I bonds)
- Non-bonding pairs on central I: Remaining 9 pairs – 6 on outer I atoms = 3 on central I
- Lone pairs on central I: 3 lone pairs

b) Calculate the number of bond pairs and lone pairs in SiH₄, H₂Se, and PH₃.

Compound	Bond Pairs	Lone pairs
SiH ₄	4	0
H ₂ Se	2	2
PH ₃	3	1

c) Predict the shapes and angles in SiH₄, H₂Se, and PH₃.

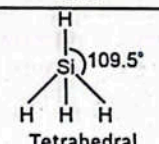
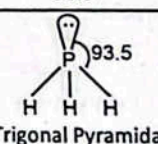
Ans.	SiH ₄	H ₂ Se	PH ₃
Type of molecule	AB ₄	AB ₂	AB ₃
No. of bond pairs	4	2	3
No. of lone pairs	0	2	1
Bond angle	109.5°	91°	93.5°
Shape of molecule	 Tetrahedral	Bent or V-shaped	 Trigonal Pyramidal

d) Predict how the bond angle in H_2S would be different from that in H_2O .

Ans.

Molecule	Electron pairs			Type	Arrangement of pairs	Geometry	Shape
	Total	B	L				
H_2O	4	2	2	AB_2	Tetrahedral	Bent or angular	
H_2S	4	2	2	AB_2	Tetrahedral	Bent or angular	

AB_5 type (Trigonal Bipyramid Geometry)

AB_5 type with five bond pairs and no lone pairs:
 PCl_5 :

- In AB_5 type molecules, repulsions between the five electron pairs can be minimized by an even distribution of electrons among the corners of a trigonal bipyramid.
- In a trigonal bipyramid, three positions lie along the corners of the planar triangle, whereas, the other two positions lie along an axis perpendicular to the plane.
- This is evident from the geometry of the PCl_5 molecule given in Figure. The angles within the plane are 120° and that between the axial atom and a planar atom is 90° .

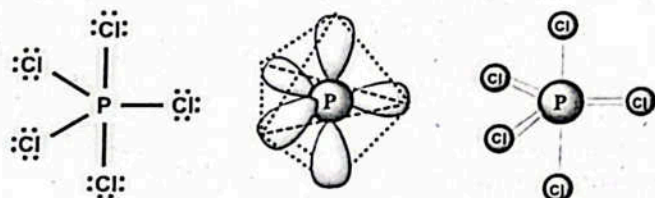

Figure Lewis structure and shape of PCl_5 molecule

Note: Just as in the AB_3 and AB_4 types, the presence of lone pairs in AB_5 system also changes the shape and the angles, but the change in this case is more dramatic.

Example: Tri-iodide ion $[I_3]^-$:

Tri-iodide ion $[I_3]^-$ is linear, although it is an AB_3 system. The central atom in this ion is the iodine atom. There are five electron pairs around the iodine atom including two bond pairs and three lone pairs. Therefore, it is an AB_3 type molecule with three lone pairs and possesses trigonal bipyramidal geometry. The lone pairs occupy the corners of the trigonal region and the iodine atoms occur on the apices, one being above and the second below the plane. However, excluding the three lone pairs, the actual shape of the tri-iodide ion is linear and the iodine atoms are farthest apart at an angle of 180° as in Figure.

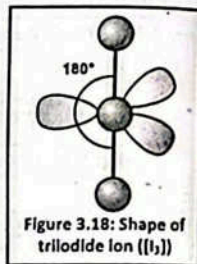

Figure 3.18: Shape of triiodide ion ($[I_3]$)

AB_6 Type Molecules (Octahedral Geometry)

AB_6 type with six bond pairs and no lone pair:

AB_6 type molecules have 6 electron pairs around the central atom. The repulsions between the electron pairs can be minimized by assuming an octahedral geometry. In this geometry, four electron pairs are at the corners of a planar square and the other two lie along an axis perpendicular to the square. All the ABA angles in this type of geometry are of 90° .

Example:

The Lewis structure of SF_6 is given in Figure, it shows that this is an AB_6 type molecule.

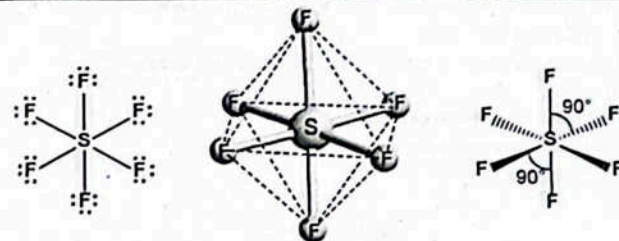

Figure: Lewis structure and octahedral shape of SF_6 with each angle of 90°

XeF_4 is an AB_6 type molecule with four bond pairs and two lone pairs. The two lone pairs remain at farthest distance at angle of 180° . Excluding the lone pairs, the actual shape of XeF_4 is square planar with all $F-P-F$ angles equal to 90° .

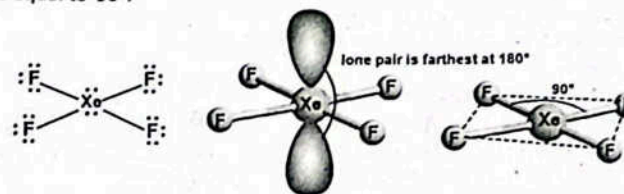

Figure: Lewis structure and square planar shape of XeF_4

QUICK CHECK 3.8

Q. Draw the Lewis structures for IF_3 and IF_5 and predict their geometry with reference to the VSEPR model.

Ans. Number of Valence electrons:

- Iodine (I): 7 valence electrons
- Fluorine (F): $3 \times 7 = 21$
- Total = 7 (I) + 21 (F) = 28 electrons

Bonding:

- 3 bonds between I and F use 6 electrons $\rightarrow 28 - 6 = 22$ electrons left.
- Distribute remaining electrons to satisfy octets on the fluorine atoms $\rightarrow 6$ electrons per F $\times 3 = 18$ electrons $\rightarrow 22 - 18 = 4$ electrons left.
- 4 electrons = 2 lone pairs on iodine.
- Electron regions around iodine: 3 bonding pairs + 2 lone pairs = 5 regions.

VSEPR Geometry:

- 5 regions \rightarrow trigonal bipyramidal electron geometry
- 2 lone pairs go in equatorial positions to minimize repulsion.
- Molecular shape = T-shaped

Structure: IF_3 Lewis Structure

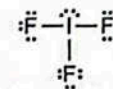

IF_5 (Iodine Pentafluoride)

Valence electrons:

- Iodine (I): 7 valence electrons
- Fluorine (F): $5 \times 7 = 35$
- Total = 7 (I) + 35 (F) = 42 electrons

Bonding:

- 5 I-F bonds use 10 electrons $\rightarrow 42 - 10 = 32$ electrons left

- 6 electrons per F \times 5 = 30 electrons \rightarrow 32 - 30 = 2 electrons left
- 2 electrons = 1 lone pair on Iodine

Electron regions around Iodine: 5 bonding pairs + 1 lone pair = 6 regions

VSEPR Geometry:

- 6 regions \rightarrow octahedral electron geometry
- 1 lone pair \rightarrow square pyramidal molecular geometry

Structure: IF₅ Lewis Structure

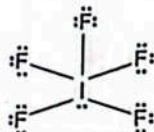

Applications of VSEPR Model in Drug Designing

Drugs are chemical substances that prevent, diagnose, or treat a disease. Drugs interact with human body at specific points, or with specific processes called targets or substrates, through their bioactive molecules called ligands. A receptor is mostly a protein that receives and responds to a ligand through binding. The examples of targets in the body are receptors, such as enzymes, proteins, nucleic acids, and cellular pathways. Each drug interacts with a specific target in the body to a different degree, this feature is called specificity of a drug or a ligand.

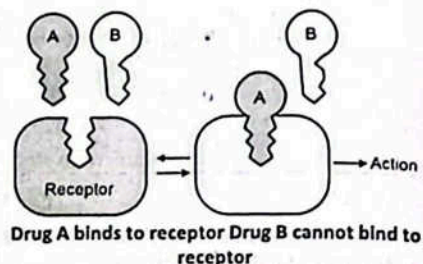

Molecular shape is an important feature that determines how a drug interacts with a biological target. Only the ligands with suitable shape can fit in the active sites of a biological target as a specific key fits in a specific lock. VSEPR model is successfully applied in determining the shapes of various biological systems, such as substrate recognition, ligand specificity or selectivity, and antibody recognition. For example, Aspirin is an analgesic drug (painkiller) used for relief from pain as a primary medicine. It interacts with an enzyme COX (cyclooxygenase) by binding to its active site through the acetyl group ($-\text{OCCH}_3$).

The shape of COX active site and that of acetyl group on Aspirin are compatible with each other as in fig. Therefore, the binding is successful to block COX, which is a cause of the pain in the body.

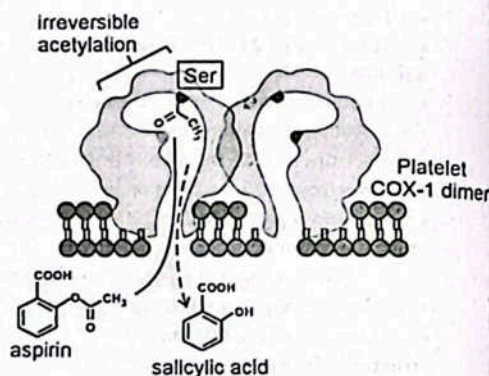

Figure: An Interaction of Aspirin with COX (Published after permission from Tulane University Press)

MOLECULAR ORBITAL THEORY (MOT)

The molecular orbital approach explains the results of quantum mechanical calculations for covalent bonding. The postulates of this theory are:

- During the formation of a molecule, the atomic orbitals of the combining atoms overlap to form new orbitals called 'molecular orbitals', which are characteristic of the whole molecule.

Rack Your Brain!

9. Why is MOT superior to VBT?

- The atomic orbitals overlap with the lobe having suitable sign of the wave function of the orbital. For example, one lobe of a p orbital is given the '+' sign and the other is marked with '-' sign.
- Two atomic orbitals overlap to form two molecular orbitals. When same sign orbitals overlap, the bonding molecular orbital (σ or π) is formed that has lower energy than the parent atomic orbital, while with opposite signs, high energy anti-bonding molecular orbital (σ^* or π^*) is formed, that has higher energy than the parent atomic orbitals.
- The number of bonds formed between two atoms after the atomic orbitals overlap, is called the bond order and is taken as half of the difference between the number of bonding electrons (say a) and anti-bonding electrons (say b).

$$\text{Bond order} = \frac{a-b}{2}$$

s-s Overlap

In the formation of H₂ molecule, two s orbitals of H atoms combine to give two molecular orbitals. The bonding molecular orbital is symmetrical about the axis joining the nuclei of the bonded atoms (nuclear axis), while the anti-bonding molecular orbital has the electron density away from the nuclei of the overlapping atoms as in Fig

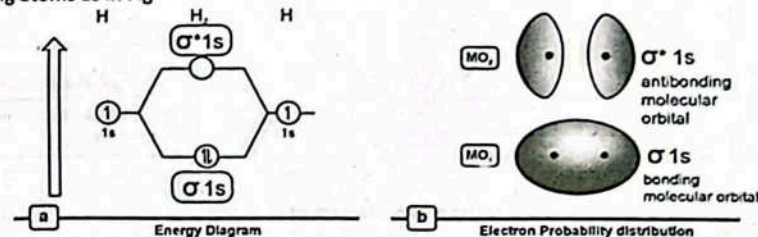

Figure: Formation of bonding and anti-bonding orbitals for the H₂ molecule

The p orbitals of an atom can combine to give:

a) Head on approach

Here, the p-orbitals of the two atoms approach along the same axis (say x-axis) as shown in Figure. This combination of atomic orbitals gives rise to $\sigma(2p_x)$ bonding and $\sigma^*(2p_x)$ antibonding molecular orbitals.

b) Sideways Approach

When the axes of two p-orbitals (i.e. p_y or p_z orbitals) are parallel to each other, they interact to form π molecular orbitals as shown in the diagram Figure. The bonding molecular orbitals $\pi(2p_y)$ or $\pi(2p_z)$ have zero electron density on the nuclear axis (called the nodal plane). On the other hand, anti-bonding molecular orbitals $\pi^*(2p_y)$ and $\pi^*(2p_z)$ have the least electron density in the inter-nuclear region.

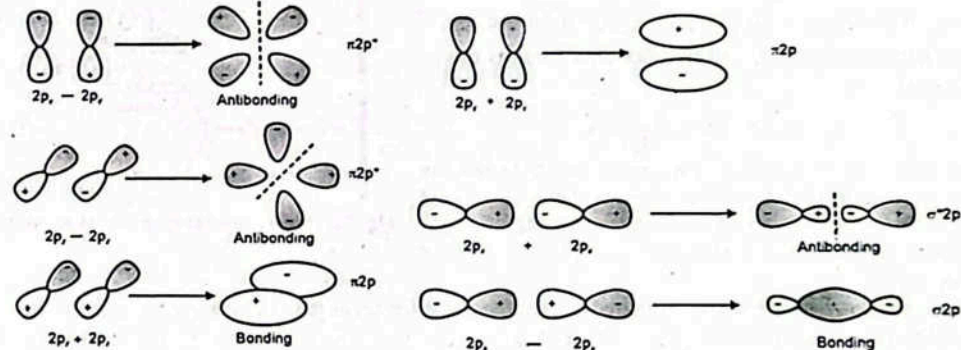

Figure: Formation of σ and π MOs from p_x , p_y and p_z orbitals

- Q. Draw the molecular orbital diagrams of the following molecules. Calculate their bond orders?
(i) H_2 (ii) He_2 (iii) N_2 (iv) O_2

⊖ Molecular Orbital Diagrams of some Diatomic Molecules and their Bond Orders

i) Helium

The electron configuration of He is $1s^2$. For a successful formation of He_2 molecule, $1s$ orbitals of two He atoms must combine to form bonding ($\delta 1s$) and anti-bonding ($\delta^* 1s$) orbitals as shown in Figure. Out of four electrons, two enter the bonding molecular orbital $\delta(1s)$ and the remaining two occupy the antibonding $\delta^*(1s)$ molecular orbital. But on calculation we discover that the bond order for He_2 is zero. Hence, He_2 molecule is not formed.

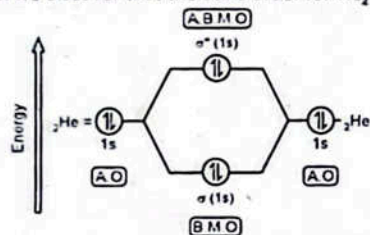

Figure: Molecular orbital diagram of He_2 molecule

$$\text{Bond order of } He_2 = \frac{2-2}{2} = 0$$

Bond order of H_2 :

The number of bonds formed between H-atoms in Hydrogen molecule may be calculated as follows:

Number of electron in bonding molecular orbital = 2
Number of electron in anti-bonding molecular orbital = 0

$$\text{Bond order} = \frac{2-0}{2} = 1$$

Rack Your Brain!
10. What bond order? Give an example.

ii) Nitrogen (N_2)

Electronic configuration of N is,

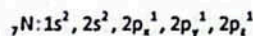

The molecular orbital diagram of N_2 based on this electron configuration is shown in the figure below (Figure). The valence shell $2s$ on both N atoms give $\sigma 2s$ and $\sigma^* 2s$ orbitals; whereas, $2p$ orbitals give six molecular orbitals which are arranged in the increasing order of energy as:

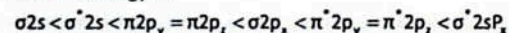

The bond order for N_2 can be calculated from its orbital diagram as:

$$\text{Bond order of } N_2 = \frac{6-0}{2} = 3$$

Therefore, there are three covalent bonds between the nitrogen atoms in this molecule. One of these is a σ bond while the other two are π bonds. Nitrogen molecule has a triple bond between its atoms.

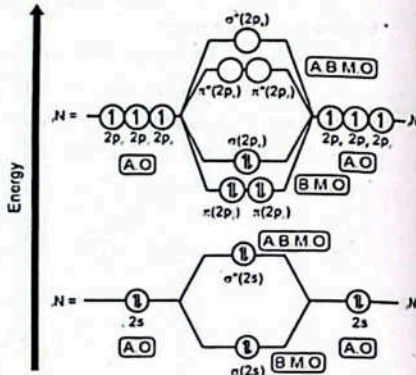
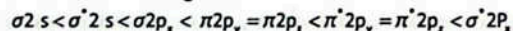

Fig: Molecular orbital diagram of N_2 molecule

iii) Oxygen, O_2

The formation of molecular orbitals in oxygen molecule is shown as follows in figure 36.

The bond energy of the MOs can be arranged as



The bond order of oxygen is $2\left(\frac{6-2}{2}\right)$, which shows the presence of one σ and one π bond between the oxygen atoms, i.e. they are linked by a double bond ($O=O$). Oxygen molecule is paramagnetic in nature, which means it is attracted by a magnetic field. Paramagnetic substances have one or more unpaired electrons in them. A substance with large number of unpaired electrons is strongly paramagnetic. MOT successfully explains the paramagnetic behavior of oxygen molecule.

The MO diagram of oxygen shows the presence of two unpaired electrons, one in $\pi^*(2p_y)$ and $\pi^*(2p_z)$ each. Due to the presence of these unpaired electrons, oxygen molecule has a net magnetic field, which interacts with the external magnetic field.

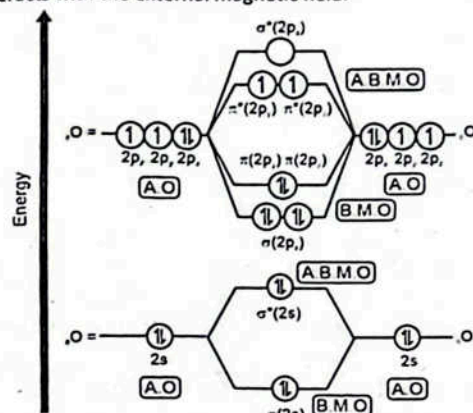
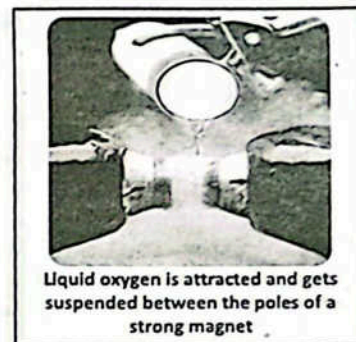

Figure: Molecular orbital diagram of O_2 molecule

Rack Your Brain!
11. Bond order of O_2 according to MOT is
(A) 1 (B) 2
(C) 3 (D) 5



Liquid oxygen is attracted and gets suspended between the poles of a strong magnet

⊖ Difference between Bonding Molecular Orbital (BMO) and Anti-Bonding

Molecular Orbital (ABMO)

Bonding Molecular Orbital (BMO)	Anti-Bonding Molecular Orbital (ABMO)
• It is formed by the addition overlapping (constructive interference of electron waves) of atomic orbitals	• It is formed by the subtraction overlapping (destructive interference of electron waves) of atomic orbitals.
• The wave function (ψ) of a BMO is given by $\psi_{BMO} = \psi_A + \psi_B$	• The wave function (ψ) of an ABMO is given by $\psi_{ABMO} = \psi_A - \psi_B$
• Its formation takes place when the lobes of atomic orbital have same sign.	• Its formation takes place when the lobes of atomic orbital have different sign.
• The energy of BMO is lesser than that of parent atomic orbitals. Thus stability of the molecule increases.	• The energy in A.B.M.O is higher than that of parent atomic orbitals. Thus stability of the molecule decreases.
• The electron density increase in the region between the nuclei of the bonded atom.	• The electron density decrease in the region between the nuclei of the bonded atom.
• Every electron in BMO contributes toward the attractive forces.	• Every electron in A.B.M.O. contributes toward the repulsive forces
• e.g. Sigma (σ) and Pi(π) in BMO.	• e.g. Sigma (σ^*) and Pi(π^*) in A.B.M.O.

Solution File Rack Your Brain!

Sr. #	Option	Explanation												
1.	B	Atoms share electrons to form a covalent bond, resulting in a stable molecule.												
2.	S.Q	Covalently bonded atoms have specific orientations in space with respect to each other. The shared electron pairs are localized between two atoms which are formed by the overlap of half-filled orbitals which have definite directions. Thus covalent bonds are directional.												
3.	D	PCl_5 has $5 + 5 = 10$ electrons (Expansion of octet)												
4.	D	BF_3 is a regular trigonal planar molecule, when dipoles cancel each other.												
5.	S.Q	<p>Sigma (σ) Bond: Sigma bond is formed by linear or head to head overlapping of partially filled orbitals. Example: Hydrogen (H_2) Molecule $H = 1s^1$</p> <div style="text-align: center;"> <p style="text-align: center;">Separated H-atoms Overlapping of orbitals Covalent bond in H_2</p> <p style="text-align: center;">s and s orbital overlap in H_2</p> </div> <p>As the two hydrogen atoms approach each other, their $1s$ orbitals overlap to form H-H bond. The electron density becomes concentrated between the two nuclei. The bond is called σ bond (sigma bond). A single bond is formed when two partially filled atomic orbital overlap in such away that the probability of finding the electron is maximum around the line joining the two nuclei.</p>												
6.	S.Q	Pi (π) Bond: Pi (π) bond is formed by parallel overlap of half-filled atomic orbitals. In π bond electronic charge density lies above and below the inter-nuclear axis and is weakly attracted by nuclei. e.g., $H_2C = CH_2$ (Ethene) has one Pi (π) bond.												
7.	S.Q	<p>MOT superior to VBT:</p> <table border="1" style="width: 100%; border-collapse: collapse;"> <thead> <tr> <th style="width: 50%;">Valence Bond Theory</th> <th style="width: 50%;">Molecular Orbital Theory</th> </tr> </thead> <tbody> <tr> <td>• According to this theory only valence electrons are involved in bond formation</td> <td>• According to this theory, all the electrons of interacting atoms are involved in bond formation</td> </tr> <tr> <td>• In VBT the two concerned atoms do not lose their individual identity</td> <td>• In MOT, the two atoms lose their individual identity</td> </tr> <tr> <td>• It does not explain the paramagnetic behaviour of molecules like O_2.</td> <td>• It explains the paramagnetic behaviour of molecules like O_2.</td> </tr> <tr> <td>• It does not give idea about the bond order</td> <td>• It give idea about bond order by which we can determine that whether the bond is single, double or triple</td> </tr> <tr> <td>• It does not explain the non-existence of He_2 molecule</td> <td>• It explains the non-existence of He_2 molecule</td> </tr> </tbody> </table>	Valence Bond Theory	Molecular Orbital Theory	• According to this theory only valence electrons are involved in bond formation	• According to this theory, all the electrons of interacting atoms are involved in bond formation	• In VBT the two concerned atoms do not lose their individual identity	• In MOT, the two atoms lose their individual identity	• It does not explain the paramagnetic behaviour of molecules like O_2 .	• It explains the paramagnetic behaviour of molecules like O_2 .	• It does not give idea about the bond order	• It give idea about bond order by which we can determine that whether the bond is single, double or triple	• It does not explain the non-existence of He_2 molecule	• It explains the non-existence of He_2 molecule
Valence Bond Theory	Molecular Orbital Theory													
• According to this theory only valence electrons are involved in bond formation	• According to this theory, all the electrons of interacting atoms are involved in bond formation													
• In VBT the two concerned atoms do not lose their individual identity	• In MOT, the two atoms lose their individual identity													
• It does not explain the paramagnetic behaviour of molecules like O_2 .	• It explains the paramagnetic behaviour of molecules like O_2 .													
• It does not give idea about the bond order	• It give idea about bond order by which we can determine that whether the bond is single, double or triple													
• It does not explain the non-existence of He_2 molecule	• It explains the non-existence of He_2 molecule													
8.	B	Geometry of SO_2 is angular because it is an example of AB_3 with one lone pair.												

9.	S.Q	<p>A bonding electron pair is attracted by both nuclei of atoms while non-bonding by only one nucleus. Because a lone pair experiences less nuclear attraction, its electronic charge is spread out more in space than that for bonding pair. As a result, the non-bonding electron pairs exert greater repulsive forces on bonding electron pairs and thus tend to compress the bond pairs. That is why the electron pairs of lone pairs occupy more space than the bond pairs.</p>	
10.	S.Q	<p>Bond Order: "Half of the difference between the number of bonding electrons and anti-bonding electrons is called the bond order." $\text{Bond Order} = \frac{\text{Number of electrons in B.M.O} - \text{Number of electrons in A.B.M.O}}{2}$ Example: Bond Order of N_2 Number of electrons in bonding molecular orbital = 6 Number of electrons in antibonding molecular orbital = 0 $\text{Bond order} = \frac{6 - 0}{2} = 3$</p>	
11.	B	Bond order of O_2 according to MOT is 2.	

Exercise

MULTIPLE CHOICE QUESTIONS (MCQs)

- Q.1** Four choices are given for each question. Select the correct choice.
- I. Chemical bond formation takes place when:
 - a) Force of attraction are equal to the force or repulsion
 - b) Force of repulsion is greater than force of attraction
 - c) Force of attraction overcomes force of repulsion
 - d) None of these
 - II. An ionic compound A^+B^- is most likely to be formed when:
 - a) Ionization energy of A is high and electron affinity of B is low.
 - b) Ionization energy of A is low and electron affinity of B is high.
 - c) Both the ionization energy of A and electron affinity of B are high.
 - d) Both the ionization energy of A and electron affinity of B are low.
 - III. Which of the following molecules has zero dipole moment?
 - a) NH_3
 - b) $CHCl_3$
 - c) H_2O
 - d) BF_3
 - IV. The numbers of σ and π bonds in the N_2 molecule are:
 - a) one σ and one π bonds
 - b) one σ and two π bonds
 - c) three σ bonds only
 - d) two σ and one π
 - V. Which of the following species has unpaired electrons in antibonding molecular orbitals?
 - a) O_2^+
 - b) N_2^-
 - c) B
 - d) F_2
 - VI. The shape of ICl_3 according to the VSEPR model is:
 - a) Tetrahedral
 - b) Trigonal planar
 - c) Trigonal bipyramidal
 - d) Square pyramidal
 - VII. Which of the following molecules has a net dipole moment?
 - a) CO_2
 - b) CS_2
 - c) SO_2
 - d) CCl_4

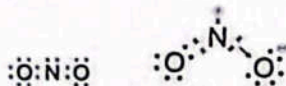
(v) NO_2 

c. Xenon is a noble gas (group 18); xenon trioxide has the following structure:

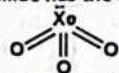

- By counting electron pairs around the central atom, explain why xenon trioxide has this shape.
- Draw a structure of xenon trioxide showing partial charges on the atoms and the direction of the dipole in the molecule.

Ans. (i) Xenon trioxide (XeO_3) has a trigonal pyramidal shape because the central xenon atom has 3 bonding pairs and 1 lone pair of electrons (total of 4 electron pairs), which adopt a tetrahedral arrangement. The lone pair repulsion distorts the structure into a pyramid with Xe at the apex.

(ii) XeO_3 has a trigonal pyramidal geometry with polar bonds. The dipole arises from the electronegativity difference ($\text{O} > \text{Xe}$), creating a net dipole toward the O atoms.

d. Explain the difference between the formation of σ and π bonds in terms of VBT.

Feature	Sigma (σ) Bond	Pi (π) Bond
Formation	Sigma (σ) bond is Formed by end-to-end (axial) overlap of orbitals.	Pi (π) bond is Formed by side-to-side (lateral) overlap of orbitals.
Orbital Overlap	s-s, s-p, or p-p orbitals along the axis.	Only p-p orbitals (unhybridized) overlapping sideways.
First or Additional	Always the first bond between two atoms.	Forms after a sigma bond in double or triple bonds.
Bond Strength	Generally stronger due to greater overlap.	Weaker than sigma due to less effective overlap.
Electron Density	Concentrated along the bond axis.	Concentrated above and below the bond axis.
Free Rotation	Allows free rotation around the bond.	Restricts rotation due to the fixed overlap orientation.

Hydrogen Hydrogen \rightarrow H_2 molecule

Symmetrical Electron Density

π bond

σ bond

e. The structure of propanone (acetone) is:

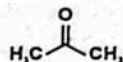

- Show how the central carbon atom forms σ and π bonds through hybridization.
- Can propanone make a hydrogen bond with water when both are intermixed?

Ans. (i)

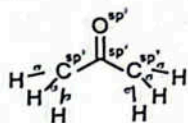
(ii) Acetone can form hydrogen bonds with water due to its polar carbonyl ($\text{C}=\text{O}$) group.

- Structure of Acetone: The oxygen (O) in the $\text{C}=\text{O}$ group is highly electronegative, creating a partial negative charge (δ^-), while the carbon carries a partial positive charge (δ^+).
- Hydrogen Bonding: Water (H_2O) acts as a hydrogen bond donor ($\text{H}^{\delta+}$), and acetone's $\text{O}^{\delta-}$ acts as an acceptor, forming:

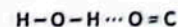

- No H-Bond Donation from Acetone: Acetone lacks H bonded directly to O/N/F (unlike alcohols), so it cannot donate H-bonds, only accept them.

f. Predict the shapes of sulfate ($[\text{SO}_4]^{2-}$), borate ($[\text{BH}_4]^-$) and tri-iodide ions ($[\text{I}_3]^-$) according to the VSEPR model.

Ans. VSEPR (Valence Shell Electron Pair Repulsion) model:

1. Sulphate Ion $[\text{SO}_4]^{2-}$

- Central atom: Sulphur (S)
- Valence electrons: 6 (from S) + 4 \times 6 (from O) + 2 (charge) = 32 electrons
- Electron pairs around S: 4 bonding pairs (no lone pairs on S)
- Electron geometry: Tetrahedral
- Molecular shape: Tetrahedral
- Bond angles: 109.5°

2. Borohydride Ion $[\text{BH}_4]^-$

- Central atom: Boron (B)
- Valence electrons: 3 (from B) + 4 \times 1 (from H) + 1 (charge) = 8 electrons
- Electron pairs around B: 4 bonding pairs (no lone pairs)
- Electron geometry: Tetrahedral
- Molecular shape: Tetrahedral
- Bond angles: 109.5°

3. Triiodide Ion $[\text{I}_3]^-$

- Central atom: Iodine (I)
- Valence electrons: 3 \times 7 = 21 + 1 (charge) = 22 electrons
- Electron pairs on central I: 2 bonding pairs (with outer I atoms), 3 lone pairs
- Electron geometry: Trigonal bipyramidal (based on 5 regions of electron density)
- Molecular shape: Linear (3 lone pairs occupy equatorial positions)
- Bond angle: 180°

Ion	Electron Geometry	Molecular Shape	Bond Angle
$[\text{SO}_4]^{2-}$	Tetrahedral	Tetrahedral	109.5°
$[\text{BH}_4]^-$	Tetrahedral	Tetrahedral	109.5°
$[\text{I}_3]^-$	Trigonal bipyramidal	Linear	180°

g. Sketch the molecular orbital pictures of $\pi(2p)$ and $\pi^*(2p)$.

Ans.

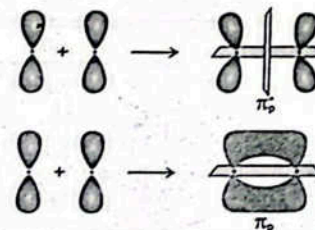
h. Sketch the hybrid orbitals and bond formation in PCl_3 , SiCl_4 and NH_4^+ .Ans. PCl_3

Formula: PCl_3
 Hybridization: sp^3
 Bond angle: 109.5°
 Geometry: Tetrahedral
 Shape: Trigonal pyramidal

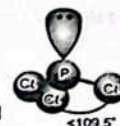
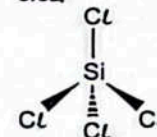
 SiCl_4 

NH_4^+
Formula: NH_4^+
Hybridization: sp^3
Bond angle: 109.5°
Geometry: Tetrahedral
Shape: Tetrahedral

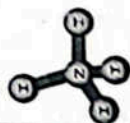

I. The structures of PF_3 and SiF_4 are given below. Redraw these with partial charges and state which is polar and which is non-polar.

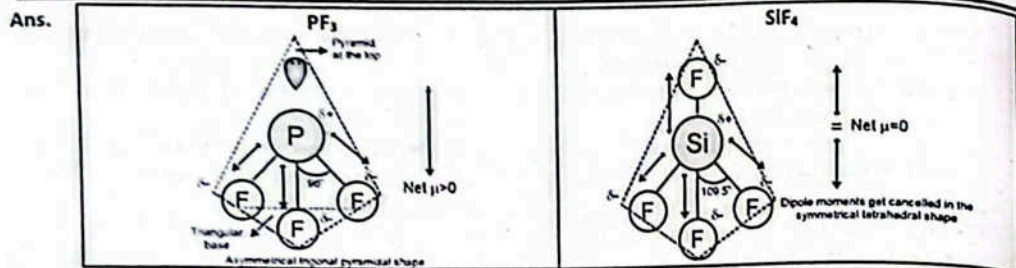
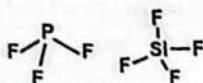

J. Draw the orbital structures of the CO_2 molecule in terms of VBT.

Ans.

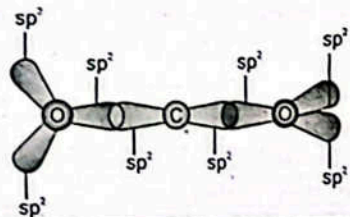

K. Draw the Lewis structures and tell whether these ions involve expanded octets?

i) ClO_4^- ii) ICl_4^- iii) NH_4^+ iv) I_3^-

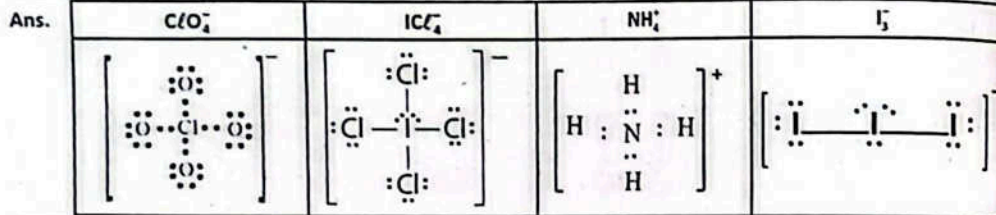

I. The bond between K and Cl is ionic but that between Si and Cl is polar covalent. Explain why?

Ans. The difference in bonding between K-Cl (ionic bond) and Si-Cl (polar covalent bond) can be explained based on the electronegativity difference between the atoms involved and their positions in the periodic table.

1. K-Cl (Ionic Bond):

- Potassium (K) is a metal in Group 1 of the periodic table, and it has a low electronegativity (0.82).
- Chlorine (Cl) is a non-metal in Group 17 and has a high electronegativity (3.16).
- Electronegativity difference: $3.16 - 0.82 = 2.34$

- When the electronegativity difference is large (usually greater than 1.7), one atom (in this case, K) will lose an electron to become a positively charged ion (K^+), while the other atom (Cl) will gain the electron to become a negatively charged ion (Cl^-). This creates an ionic bond where the electrostatic attraction between the oppositely charged ions holds them together.
 - K-Cl: Large electronegativity difference \rightarrow Ionic bond (electron transfer).
2. Si-Cl (Polar Covalent Bond):
- Silicon (Si) is a metalloid with an electronegativity of 1.90.
 - Chlorine (Cl), has an electronegativity of 3.16.
 - Electronegativity difference: $3.16 - 1.90 = 1.26$
 - When the electronegativity difference is moderate (between 0.4 and 1.7), the electrons are not completely transferred as in ionic bonds, but instead, they are shared unequally between the two atoms.
 - In this case, chlorine attracts the shared electron pair more strongly than silicon, creating a polar covalent bond. The Cl atom becomes partially negative (δ^-), and the Si atom becomes partially positive (δ^+). The bond is polar because of the unequal sharing of electrons.
 - Si-Cl: Moderate electronegativity difference \rightarrow Polar covalent bond (unequal electron sharing).

m. SO_2 is a polar molecule but SO_3 not. Justify.

Ans. The difference in polarity between SO_2 (Sulphur dioxide) and SO_3 (Sulphur trioxide) can be explained by the molecular geometry and symmetry of the molecules.

1. SO_2 (Sulphur Dioxide) – Polar:

SO_2 is Bent or V-shaped (due to sp^2 hybridization of the central Sulphur atom). The bond angle between the oxygen atoms is approximately 119° . The Sulphur atom has one lone pair in SO_2 , which influences the shape and causes a bent molecular geometry. Oxygen is more electronegative than Sulphur, creating a dipole moment pointing towards the oxygen atoms. Due to the bent shape, the individual bond dipoles do not cancel each other out, resulting in a net dipole moment, making SO_2 a polar molecule.

2. SO_3 (Sulphur Trioxide) – Nonpolar:

SO_3 is Trigonal planar (due to sp^2 hybridization of the central Sulphur atom). The bond angles between the oxygen atoms are exactly 120° , forming a flat, symmetric structure. The Sulphur atom in SO_3 has no lone pairs. The molecule is highly symmetric, with the three oxygen atoms arranged symmetrically around the central Sulphur atom, and the bond dipoles in each C=O bond cancel each other out. This results in no net dipole moment, making SO_3 a nonpolar molecule.

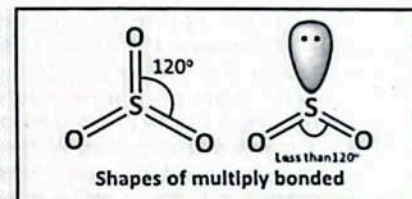

n. Which of O_2^+ and O_2^- would be paramagnetic? Give reason in the light of MOT.

Ans. i) O_2^+

$$\text{O}_2^+ = 1s^2, 2s^2, 2p_x^1, 2p_y^1, 2p_z^1$$

$$\text{Bond order} = \frac{8-2}{2} = \frac{6}{2} = 3$$

There are three bonds between to O^+ ions in O_2^+

It is diamagnetic because there are no unpaired electrons in antibonding molecular orbitals

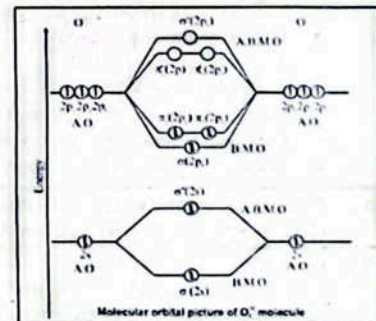

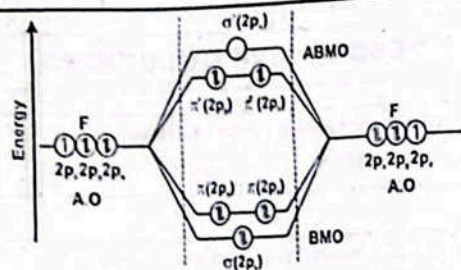
Molecular orbitals energy level diagram of F_2

$$F_2 = (\sigma 1s)^2 (\sigma^* 1s)^2 (\sigma 2s)^2 (\sigma^* 2s)^2 (\sigma 2p_x)^2 (\pi 2p_y)^2 (\pi 2p_z)^2 = (\pi^* 2p_x)^2 = (\pi^* 2p_y)^2$$

$$\text{Bond order} = \frac{10 - 8}{2} = 1$$

ADDITIONAL SLOs BASED MCQs

- Which atom donates a lone pair in the formation of a dative bond in H_3O^+ ?
A) One of the hydrogen atoms B) The oxygen atom
C) A proton D) Water molecule
- Which ion has an expanded octet around the central atom?
A) NH_4^+ B) NO_3^- C) SO_4^{2-} D) OH^-
- Which of the following pairs will form a covalent bond?
A) Na and Cl B) K and F C) H and Cl D) Mg and O
- Which statement about dipole moments is true?
A) They depend only on bond length
B) They depend only on molecular mass
C) They result from equal sharing of electrons
D) They arise from bond polarity and molecular shape
- The bond angle in a trigonal planar molecule is:
A) 90° B) 104.5° C) 109.5° D) 120°
- Valence bond theory explains:
A) Ionic bond formation B) Molecular shapes
C) Bond formation through orbital overlap D) Electron transfer
- What is the shape of the ammonium ion (NH_4^+)?
A) Linear B) Trigonal pyramidal C) Tetrahedral D) Bent
- Which hybridization is present in methane (CH_4)?
A) sp B) sp^2 C) sp^3 D) sp^3d
- In ethene (C_2H_4), the carbon atoms are:
A) sp hybridized B) sp^2 hybridized C) sp^3 hybridized D) Unhybridized
- What is the bond angle in a molecule with sp^3 hybridization?
A) 120° B) 109.5° C) 180° D) 90°
- Which of the following supports paramagnetism in oxygen (O_2)?
A) Bond length B) Lone pairs
C) Unpaired electrons in antibonding orbitals D) Resonance
- Which orbital in O_2 contains unpaired electrons?
A) $\sigma(2s)$ B) $\sigma(2p_z)$ C) $\pi^*(2p_x)$ and $\pi^*(2p_y)$ D) $\pi(2p_y)$

- Electronegativity values are useful to predict:
A) Number of protons B) Bond lengths C) Bond polarity D) Boiling point
- Which factor increases the electronegativity of an element?
A) Increased atomic size B) Greater shielding effect
C) Higher nuclear charge D) More electron shells
- Which element has lower electronegativity due to shielding?
A) F B) O C) Li D) Cs

Answer Key with Explanations

Sr.No.	Option	Explanations
1.	B	Oxygen donates a lone pair to a proton (H^+) in H_3O^+ .
2.	C	Sulphur in SO_4^{2-} exceeds the octet due to available d orbitals.
3.	C	H and Cl have a small electronegativity difference \rightarrow covalent bond.
4.	D	Both electronegativity difference and molecular geometry affect dipole moments.
5.	D	Trigonal planar molecules have bond angles of 120° .
6.	C	Valence bond theory describes covalent bonding as orbital overlap.
7.	C	NH_4^+ has 4 bonding pairs \rightarrow tetrahedral shape.
8.	C	CH_4 has four sigma bonds \rightarrow sp^3 hybridization.
9.	B	Each carbon in ethene forms 3 sigma bonds \rightarrow sp^2 hybridization.
10.	B	sp^3 hybridization leads to a tetrahedral geometry with 109.5° angles.
11.	C	MOT explains O_2 's Paramagnetism due to unpaired electrons in π^* orbitals.
12.	C	$\pi^*(2p_x)$ and $\pi^*(2p_y)$ each have one unpaired electron in O_2 .
13.	C	The difference in electronegativity between atoms determines bond polarity.
14.	C	Higher nuclear charge attracts bonding electrons more strongly.
15.	D	Cesium has many inner shells, causing high shielding and low electronegativity.

ADDITIONAL SHORT ANSWER QUESTIONS

Q.1 Define ionic bond with example.

Ans. Ionic Bond or Electrovalent Bond:

"The electrostatic force of attraction between oppositely charged ions i.e. cation and anion is called ionic bond or electrovalent bond."

IA group form ionic bond with VIIA

IA	VIIA
Li ⁺	F ⁻
Na ⁺	Cl ⁻
K ⁺	Br ⁻
Rb ⁺	I ⁻

Q.2 Define bond energy. What are factors influencing bond energy?

Ans. Bond Energy:

"The average amount of energy required to break all bonds of a particular type in one mole of the substance is called the bond energy."

Factors Affecting Bond Energy:

Bond energy is a measure of the strength of a bond. The strength of a bond depends upon the following factors.

- Electronegativity Difference of Bonded Atoms:** Greater the electronegativity difference of bonded atom, more will be the polarity of bond and higher will be its bond energy.
- Sizes of the Atoms:** Bond energy decreases with increase in the atomic radii.

Bond	Bond Energy (kJmol ⁻¹)
H-F	567
H-Cl	431
H-Br	366
H-I	299

- Bond Length:** The bonds with higher bond energy values have shorter bond lengths. The bond energies of C to C bonds being in the order C=C>C=C>C-C. Their bond lengths are in the reverse order i.e. C-C>C=C>C=C.

- Bond Polarity:** Generally, a polar covalent bond is stronger than a non-polar covalent bond.

Q.3 How do you compare the bond strengths of polar and non-polar molecules?**Ans. Polar and Non-Polar Molecules and Their Strength:**

In polarity bonded atoms in molecules have partial positive and partial negative centres because of difference of electronegativity. Additional attractive force is created between bonded atoms due to dipole formation. As a result bond is stronger than it is expected.

Example: Bond energy (Calculated) for H-Cl = 336 kJ/mol⁻¹

Bond energy (observed) for H-Cl = 432 kJ/mol⁻¹

Difference in Bond energy = Bond energy (observed) - Bond energy (calculated)

Difference in Bond energy = 432 - 336 = 96 kJ mol⁻¹

Difference in Bond energy is created due to extra strength of polar bond/ionic character of molecule.

On the other hand, no dipole formation occurs in non-polar molecule, so bond is comparatively weaker e.g., bond energy of Cl-Cl = 242 kJ mol⁻¹.

Hence, we conclude that a polar bond is stronger than non-polar bond due to ionic character present in it.

Q.4 Differentiate between co-ordinate covalent bond and covalent bond.**Ans. Differences between Co-ordinate Covalent Bond and Covalent Bond:**

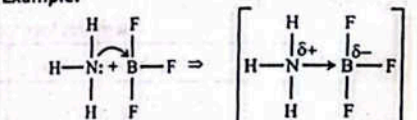
Covalent Bond	Coordinate Covalent Bond
(i) The bond which is formed by the mutual sharing of electrons between two atoms is called as covalent bond.	(i) A coordinate covalent bond is formed between two atoms when the shared pair of electrons is donated by one of the bonded atoms.
(ii) Single covalent bond is represented by a single line, double covalent bond by two lines and triple covalent bond by three lines.	(ii) Coordinate covalent bond is represented by an arrow pointing from the donor atom to the acceptor atom.
Example: $H^{\bullet} \times H \rightarrow H-H$ $\cdot\ddot{C}\cdot \times \cdot\ddot{C}\cdot \rightarrow Cl-Cl$	Example: 

Q.5 What is basic assumption of VSEPR theory?**Ans. The Basic Assumption of VSEPR Theory:**

The valence electron pairs (lone pairs and the bond pairs) are arranged around the central atom to remain at a maximum distance apart to keep repulsions at a minimum.

(Note: This way of arrangement of electron pairs gives minimum energy and maximum stability to the molecules).

Q.6 Why are the bond angles of H₂O and NH₃ not equal to 109.5° like that of CH₄ although oxygen and nitrogen atoms are sp³ hybridized?



Ans. According to VSEPR theory, the shape of a molecule is decided on the basis of repulsions between of lone pairs and bond pairs around the central atom. Although N and O are sp³ hybridized yet they differ in bonding from C compounds with sp³ hybridization according to VSEPR theory. The description of these molecules is as follows:

Properties	CH ₄	NH ₃	H ₂ O
Type of molecule	AB ₄	AB ₃	AB ₂
No. of bond pairs	4	3	2
No. of lone pairs	0	1	2
Shape of molecule	Tetrahedral	Pyramidal	Angular
Bond angle	109.5°	107.5°	104°
Reason of difference	Structure is regular due to only bond pair-bond pair repulsions	Structure is distorted due to lone pair as Lone pair-Bond pair repulsion effects more than Bond pair-Bond pair repulsions so bond angle is reduced.	Here due to two lone pairs, Lone pair-Lone pair has a greater effect so angle is further reduced to 104°.

Q.7 Predict the shapes of following molecules according to VSEPR theory

- (i) H₂S (ii) H₂O (iii) BeCl₂

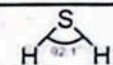
Ans.

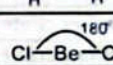
Molecule	Electron Pairs			Type	Arrangement of Pairs	Geometry	Shape
	T	B	L				
H ₂ S	4	2	2	AB ₄	Tetrahedral	Bent or angular	
H ₂ O	4	2	2	AB ₄	Tetrahedral	Bent or angular	
BeCl ₂	2	2	0	AB ₂	Linear	Linear	

Q.8 Why does lone pair of electrons occupy more space as compared to bond pair?

Ans. A bonding electron pair is attracted by both nuclei of atoms while non-bonding by only one nucleus. Because a lone pair experiences less nuclear attraction, its electronic charge is spread out more in space than that for bonding pair. As a result, the non-bonding electron pairs exert greater repulsive forces on bonding electron pairs and thus tend to compress the bond pairs. That is why the electron pairs of lone pairs occupy more space than the bond pairs.

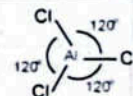
**Q.9 Write two points of Valence Bond theory.****Ans. Points of Valence Bond Theory**

- A bond between two atoms is formed by the overlap of half-filled orbitals of two atoms. The two overlapping atomic orbitals retain their identities.
- The two overlapping orbitals must have electrons of opposite spin.

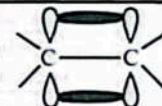

Q.10 Explain the structure of CH_4 on the basis of sp^3 hybridization.

Ans. Hybridization:

"The process of mixing of atomic orbitals having different shapes and energies to form hybrid orbitals with same shape and almost same energy is called Hybridization".

- Types: 1. sp^3 - hybridization
2. sp^2 - hybridization
3. sp - hybridization

Structure of CH_4 : Methane molecule is formed by the overlap of sp^3 hybrid orbitals of carbon with $1s$ orbitals of four hydrogen atoms separately to form four sigma bonds. The molecule thus formed, possesses a tetrahedral geometry. The four C-H bonds which result from sp^3 -s overlaps are directed towards the corners of a regular tetrahedron. The tetrahedral structure of CH_4 has four faces, four corners, six edges and six bond angles of 109.5° .

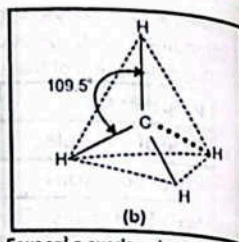

Four sp^3 -s overlaps in tetrahedral structure of CH_4 molecule

Q.11 Draw molecular orbital picture of N_2 molecule and also calculate its bond order.

Ans. Molecular Orbital Picture of N_2 Molecule:

The molecular orbital structure of N_2 molecules is shown

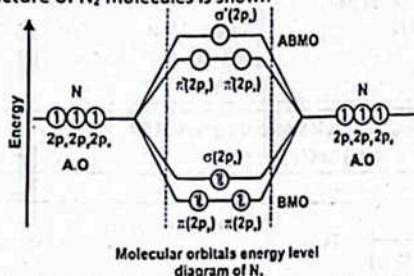

Since no unpaired electron is present in MOs so N_2 molecule shows diamagnetic behaviour.

Bond Order:

$$\text{Bond order} = \frac{\text{No. of electrons in BMO} - \text{No. of electrons in ABMO}}{2} = \frac{6 - 0}{2} = 3$$

So, the bond order of nitrogen is 3.

Q.12 Differentiate between Bonding and Antibonding Molecular Orbitals.

Ans. Differences between Bonding and Antibonding Molecular Orbitals:

Bonding Molecular Orbital (BMO)	Anti-Bonding Molecular Orbital (ABMO)
It is formed by the addition overlapping (constructive interference) of atomic orbitals.	It is formed by the subtraction overlapping (destructive interference) of atomic orbitals.
The wave function (ψ) of a BMO is given by $\psi_{\text{BMO}} = \psi_A + \psi_B$	The wave function (ψ) of an ABMO is given by $\psi_{\text{ABMO}} = \psi_A - \psi_B$
Its formation takes place when the lobes of atomic orbital have same sign.	Its formation takes place when the lobes of atomic orbital have different sign.
The energy of BMO is lesser than that of parent atomic orbitals.	The energy in A.B.M.O is higher than that of parent atomic orbitals.
The electron density is high in the region between the nuclei of the bonded atom.	The electron density is lower in the region between the nuclei of the bonded atom.
Every electron in BMO contributes toward the attractive forces.	Every electron in A.B.M.O. contributes toward the repulsive forces
e.g., Sigma (σ) and Pi (π) in BMO.	e.g., Sigma (σ^*) and Pi (π^*) in A.B.M.O.

Q.13 Differentiate between a Sigma and Pi bond.

Ans. Differences between a Sigma and Pi Bond:

Sr. #	Sigma bond (σ)	Pi bond (π)
(i)	Sigma bond is formed by linear or head to head overlapping of partially filled orbitals.	Pi bond is formed by parallel or side to side overlap of atomic orbitals.
(ii)	Representation of sigma bond is ' σ '.	Representation of Pi bonds is π .
(iii)	Electronic charge density is present on bond axis between the two nuclei.	Electronic charge density is present above and below bond axis of two nuclei.
(iv)	Charge density of σ -bond is comparatively less diffused than π and due to stronger nuclear attraction.	Charge density of π bond is more diffused due to lesser nuclear attraction.
(v)	Sigma bond is stronger.	π bond is weaker.
(vi)	σ -bond is comparatively inert.	π bond is comparatively reactive.
(vii)	Bonded atoms always form σ -bond firstly and then π -bond if necessary.	π -bond formation is preceded by σ -bond formation.
(viii)	Examples: H-H σ -bond	$\text{O} \begin{matrix} \sigma \\ \pi \end{matrix} \text{O}$

Q.14 Define dipole moment and write the units of dipole moment.

Ans. The product of electric charge (q) and the distance between the positive and negative centers (r) is called dipole moment.

$$\mu = q \times r$$

Units:

(i) The common unit of dipole moment is Debye (D).

(ii) In S.I. the units of dipole moment are mC.

Relationship between Debye (D) and mC: $1\text{D} = 3.336 \times 10^{-30}\text{mC}$

Q.15 Define bond length. Give two factors affecting bond length.

Ans. Bond Length: "The distance between the nuclei of two atoms forming a covalent bond is called the bond length."

Factors Affecting Bond Length

i. Electronegativity Difference: With an increase in electronegativity difference between the bonded atoms, the bond becomes shortened.

Case - II: e.g. Si-F bond length in SiF_4 is found to be 154-159 pm, whereas the addition of their covalent radii (Si = 117pm and F = 64 pm) give Si-F bond length to be equal to 181 pm. The calculated values are almost always higher due to electronegativity differences. The ionic character results in shortening of the bond length due to force of attraction between the polar ends.

ii. Hybridization: Hybridization scheme involved, also explains the shortening of bonds due to the predominant participation of s-orbitals. Since the 2s-orbital of carbon has smaller mean radius than the 2p-orbitals, it would be expected that greater the s character in the hybrid orbitals used, the shorter will be the bond distance.

Example: C-C bond lengths are 154, 133 and 120 pm for ethane, ethene and ethyne, respectively where s-orbital contribution increases from sp^3 to sp .

