

- Each G3P is oxidized to its acidic form. In this step, two hydrogen atoms (containing two high-energy electrons) are removed from G3P and transferred to NAD^+ . At the same time, an inorganic phosphate group is also added to G3P. It results in a molecule of 1,3-bisphosphoglyceric acid (1,3-BPGA).
- The phosphate group is transferred from (1,3-BPGA) to ADP. So, (1,3-BPGA) changes into 3-phosphoglyceric acid (3-PGA). A molecule of ATP is also formed in this step.
- 3-PGA is converted to 2-phosphoglyceric acid (2-PGA).
- 2-PGA is dehydrated (water removed) into phosphoenol pyruvic acid (PEP).
- PEP gives up its high energy phosphate to convert a second molecule of ADP to ATP. As a result PEP is changed into pyruvic acid.

Stage (ii): Pyruvic acid Oxidation

- Pyruvic acid does not directly participate in Krebs cycle. It has to go through the following changes before entering the Krebs cycle.
- Glucose enters cells from the tissue fluid by passive transport using a specific glucose carrier. This carrier can be controlled (gated) by hormones such as insulin.
- Pyruvic acid can also be turned back into glucose by reversing glycolysis. This is called gluconeogenesis.
 - A molecule of carbon dioxide is removed from pyruvic acid. So, it changes into acetaldehyde.
 - Acetaldehyde is oxidized (hydrogen is removed) to make acetyl group. A molecule of NAD^+ is reduced to NADH.
 - Acetyl group combines with coenzyme-A (CoA) to form acetyl-CoA (Fig).

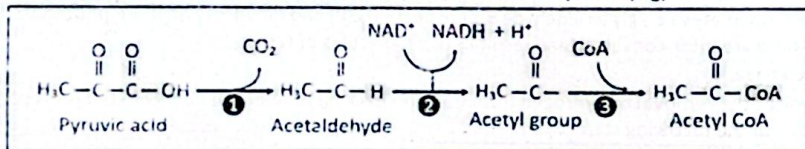

Figure: Pyruvic acid oxidation

Check Understanding!
16. What is the importance of regenerating NAD^+ during fermentation?

Q. Describe how Krebs cycle is the completion of the oxidation of glycolytic products. **[Exercise L.O.10]**

Stage (iii): Krebs Cycle (Citric Acid Cycle)

- Acetyl-CoA now enters a cyclic series of chemical reactions during which oxidation process is completed (Fig).
- Much of this cycle was worked out by a British biochemist.
- Sir Hans Krebs so it is called the Krebs cycle. It is also called the citric acid cycle, after the six-carbon citric acid molecule formed in its first step.
- All steps of the citric acid cycle occur in mitochondria. It involves following reactions.

Reactions Involve in Krebs Cycle:

- Acetyl-CoA splits into CoA and acetyl group. The acetyl group combines with a four-carbon molecule, oxaloacetic acid. As a result a six-carbon citric acid is formed.
- Citric acid undergoes an oxidative decarboxylation reaction. It is decarboxylated (releasing a molecule of CO_2) and then oxidized (reducing an NAD^+ to NADH). So, a five-carbon molecule called alpha-ketoglutaric acid is formed.
- Alpha-ketoglutaric acid undergoes further oxidation and decarboxylation. It results in the formation of a four-carbon molecule i.e., succinic acid. Succinic acid joins with CoA and makes succinyl CoA.

- The release of carbon dioxide takes place before oxygen is involved.
- It is therefore not true to say that respiration turns oxygen into carbon dioxide.
- It is more correct to say that respiration turns glucose into carbon dioxide, and oxygen into water.

Check Understanding!
17. During pyruvate oxidation, which molecule is released as a by-product?
A) NAD^+ B) CO_2
C) Glucose D) Oxygen

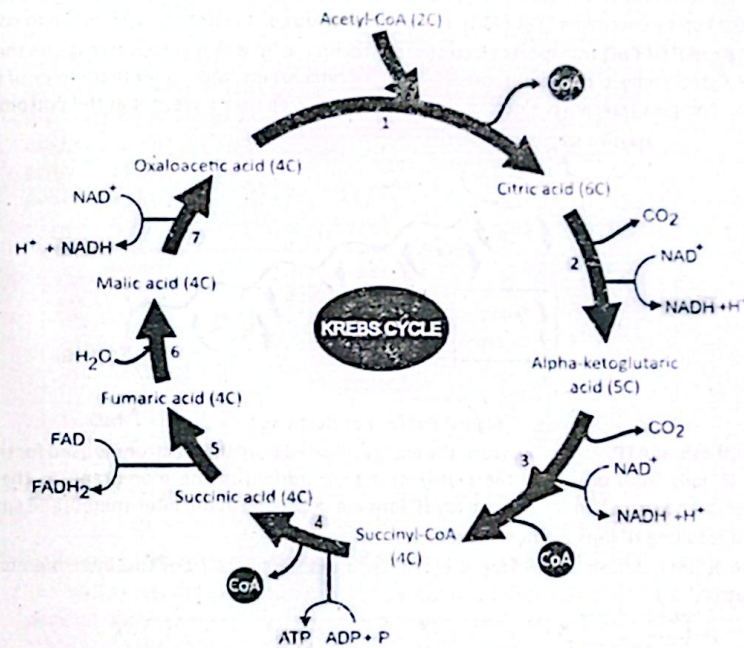

Figure: Krebs cycle

- The bond between succinic acid and CoA is a high-energy linkage. It again splits into CoA and succinic acid. The energy released in this reaction, is used in making a molecule of ATP.
- Succinic acid is oxidized to fumaric acid. When its two hydrogen atoms are removed, the free energy is not enough to reduce NAD^+ . So, a different electron acceptor i.e., the coenzyme flavin adenine dinucleotide (FAD) is used and is reduced to FADH_2 .
- In order to regenerate oxaloacetic acid, a molecule of water added to fumaric acid and it is changed to malic acid.
- Malic is oxidized to produce oxaloacetic acid. The hydrogen and electrons released from malic acid convert an NAD^+ to NADH. This completes the cycle and oxaloacetic acid is now free to bind another molecule of acetyl CoA to initiate the cycle.

Q. Explain the passage of electron through electron transport chain. **[Exercise L.O.11]**

Q. Define chemiosmosis. How would you relate it with electron transport chain? **[Exercise L.O.12]**

Stage (iv): Electron Transport Chain and Chemiosmosis

- In electron transport chain the electrons are transferred from the reduced coenzymes i.e., NADH and FADH_2 to a series of electron carriers and finally to oxygen. After getting the electrons, the oxygen attaches with hydrogen ions and forms water (Fig.).
- The transfer of electrons to the series of carriers of electron transport chain results in oxidation and reduction reactions i.e., a carrier is oxidized when it loses electrons and next carrier is reduced when it gets electrons. Electrons lose energy during this carrier-to-carrier transport.
- Chemiosmosis:** A mechanism in which membranes are used to couple redox (oxidation + Reduction) reactions with the synthesis of ATPs.

- You have seen that in redox reactions electrons and hydrogen ions are removed from substrates and transferred to coenzymes NAD^+ and FAD .

Check Understanding!
18. Why is oxaloacetate important in the Krebs cycle?

- **Pathway of Electrons:** The electron transport chain of respiration is built in the inner membrane of the mitochondrion. At the start of electron transport chain, NADH is oxidized and the released electrons are taken up by coenzyme Q. If FADH₂ is also to be oxidized, its electrons also move to coenzyme Q.
- The reduced CoQ transports electrons to cytochrome 'b' which in turn transports them to cytochrome 'c'. Cytochrome 'c' then transports electrons to cytochrome 'a' complex (a complex of two cytochromes). This complex transports electrons to an atom of oxygen that is present at the bottom end of the chain.

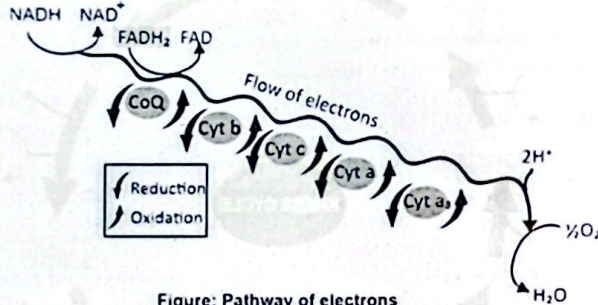

Figure: Pathway of electrons

- **Synthesis of ATP:** As redox occurs, the energy released from the electrons is used for the active transport of H⁺ ions from one side (the matrix of mitochondrion) of the membrane to the other (the inter-membrane space). In this way, many H⁺ ions are deposited in the inter-membrane space.
- The resulting H⁺ ions gradient stores potential energy.
- The H⁺ ions diffuse back along their concentration gradient from the inter-membrane space to the matrix (Fig.)

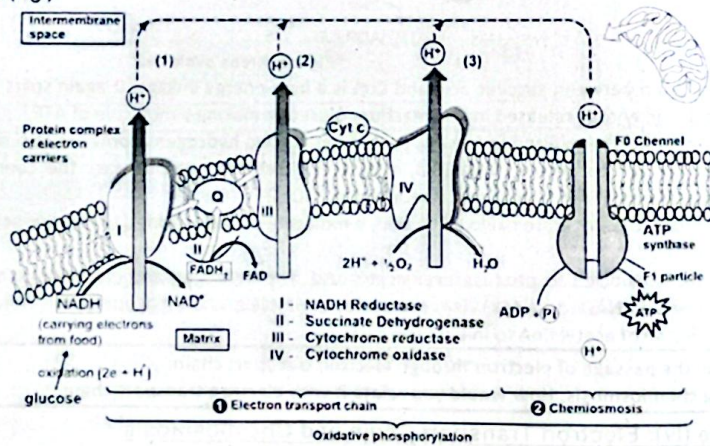

Figure: Electron transport chain and chemiosmosis in mitochondrion

- On their way they pass through a special protein known as ATP synthase.
- As the H⁺ ions move through this protein, their flow drives the synthesis of ATP (Fig).
- Oxidation of one molecule of NADH in electron transport chain produces three ATP. While oxidation of one FADH₂ produces two ATP. At the end, the two hydrogen ions are taken by the oxygen atom which has also taken two electrons to form water.

Check Understanding!

19. Which complex in the ETC accepts electrons directly from NADH?

A) Complex I B) Complex II
C) Complex III D) Complex IV

- (a) Chemiosmotic Phosphorylation (chemiosmosis) (b) Substrate-level phosphorylation

➤ **Substrate-level Phosphorylation:**

- Cells generate ATP by phosphorylation i.e. adding a phosphate group to ADP. A cell has two ways of phosphorylation.
- **Substrate-level phosphorylation** is much simpler than chemiosmosis. It does not involve any membrane or electron transport chain. In this process, an enzyme transfers a phosphate group from an organic substrate molecule to ADP. The products are a new organic molecule and a molecule of ATP. For example; during the last step of glycolysis, an enzyme transfers phosphate group from phosphoenol pyruvic (PEP) acid to ADP.
- As a result, ADP becomes ATP and PEP is changed into pyruvic acid. Substrate-level phosphorylation accounts for only a small percentage of the ATP that a cell generates. This reaction can be shown as:

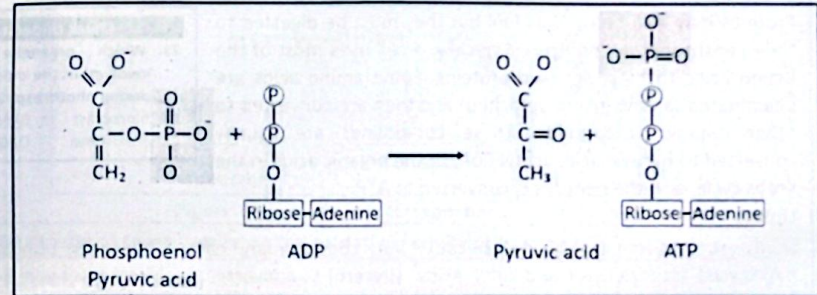

➤ **Overview of the energy extracted from the Oxidation of Glucose**

- The NADH and FADH₂ produced during glycolysis and Krebs cycle pass on their energy-rich electrons to the electron transport chain and ATPs are produced.
- The NADH molecule generated in the Krebs cycle causes the production of three ATP molecules, during chemiosmosis.

Check Understanding!

20. Where does substrate-level phosphorylation occur during cellular respiration?

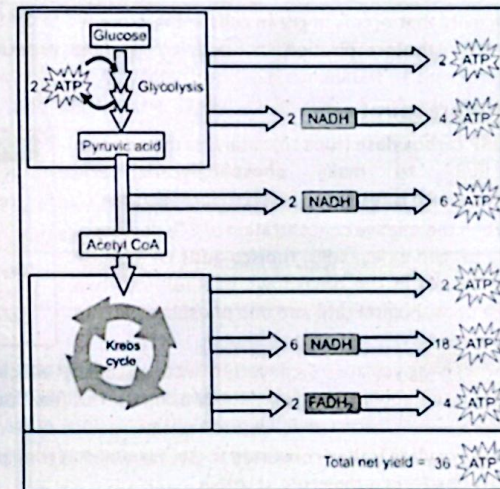

Figure: An overview of the energy extracted from the aerobic oxidation of glucose

- Glycolysis takes place in cytoplasm and the NADH, produced during glycolysis, have to be transported across the mitochondrial membrane. It costs one ATP molecule per NADH. Thus, each NADH of glycolysis produces two ATP molecules in the final balance sheet instead of three.

- Each FADH_2 molecule leads to the production of two ATP molecules.
- In this way, aerobic oxidation of glucose yields a net profit of **36 ATP molecules**.
- While during the glycolysis of anaerobic oxidation only **2 ATP molecules** are generated. Thus, aerobic oxidation is **18 times** more efficient than anaerobic (Fig.).

Q. Through which ways proteins and fats enter cellular respiration? (Exercise L-0.10)

Other Organic Molecules as fuel for Cellular Respiration:

- Free glucose molecules are **not common** in our diet. Rather, we consume sucrose and other disaccharides, starch, and fats and proteins.

(1) Proteins:

- Proteins may also be used as fuel but they must be digested to their constituent amino acids. Typically, a cell uses most of the amino acids to make its own proteins. Some amino acids are deaminated (amino group detached) and then are converted to other organic compounds. These compounds are usually converted to pyruvic acid, acetyl CoA, or the organic acids in the Krebs cycle, and their energy is converted to ATP.

Check Understanding!

21. Which organelle is primarily involved in the oxidation reactions during photorespiration?

A) Chloroplast B) Mitochondrion
C) Peroxisome D) Golgi apparatus

(2) Lipids:

- Lipids are excellent cellular fuel because they contain many carbon-hydrogen bonds. They are first hydrolysed into glycerol and fatty acids. Glycerol is converted to glyceraldehyde 3-phosphate, an intermediate in glycolysis, while the fatty acids are changed into acetyl CoA. In this way both the fatty acids and the glycerol enter cellular respiration.

PHOTORESPIRATION

Q. Define photorespiration and present it in proving that "photosynthesis is not perfect". (Exercise L-0.10)

- The respiratory activity that occurs in green cells in the presence of light, resulting in release of carbon dioxide is termed as **photorespiration**. It needs oxygen and produce CO_2 and H_2O like aerobic respiration.

Mechanism of Photorespiration:

- We know that RuBP carboxylase (rubisco) catalyses the addition of CO_2 to RuBP to make phosphoglyceric acid (phosphoglycerate), which is further reduced to form glucose.
- **In Chloroplast:** When the relative concentration of CO_2 decreases and there is more oxygen in leaf cells, rubisco adds O_2 in RuBP instead of CO_2 . It results in the breakdown of RuBP into two molecules i.e., one phosphoglycerate and one phosphoglycolate (a two-carbon molecule).
- **In Peroxisome:** Phosphoglycolate is converted into glycolate, which moves from chloroplast to peroxisome. Here, it is metabolized to glyoxylate by using O_2 . This reaction also produces toxic hydrogen peroxide (H_2O_2).
- **In Mitochondrion:** Glyoxylate is then converted to glycine, which is transported to mitochondrion. Here two molecules of glycine form a molecule of serine.
- **Again in Peroxisome:** Serine is then transported to peroxisome. Here, it is converted to glycerate.
- **Again in Chloroplast:** From peroxisome, glycerate moves to chloroplast, where it is changed to phosphoglycerate which can re-enter Calvin cycle.

Recalling

- During carbon fixation, rubisco combines three molecules of CO_2 with three molecules of RuBP and makes six molecules of 3-phosphoglyceric acid (3-PGA).
- However, ATP is not produced during photorespiration.

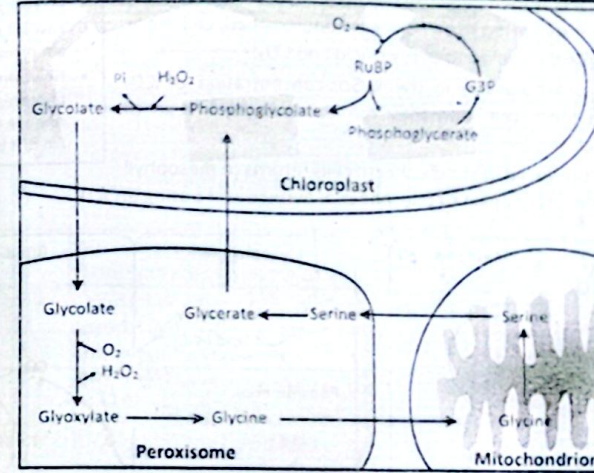

Figure: Reactions of photorespiration

Q. What are the effects of temperature on the oxidative activity of Rubisco? (Exercise L-0.10)

Disadvantages of Photorespiration

- **Loss of Carbon Fixation + Reduction in Yields:** Plants that use Calvin cycle to fix carbon are called C-3 plants. When photorespiration occurs in these plants, they lose **between a 25% to 50%** of their fixed carbon. It results in reduction in their yields. The rate of photorespiration also depends on temperature. At higher temperatures the oxidative activity of rubisco increases than its carbon fixing activity.
- In tropical climates, especially those in which the temperature is often above 28°C , the problem is a severe and it has a major negative impact on agricultural yields.

Early Atmosphere Has A Little O_2

- When photosynthesis first evolved, there was little oxygen in the atmosphere. So, there was little or no photorespiration. After millions of years, free O_2 accumulated in the atmosphere and competition started between CO_2 and O_2 for the same active site of rubisco. It led to the problem that photorespiration now poses.

Adaptations to the Problems of Photorespiration

- Plants of warmer climates evolved the following two ways to deal with the problem of photorespiration.

- C-4 plants carry out C-4 as well as C-3 photosynthesis.

Q.16 How is the process of C4 photosynthesis an adaptation to deal with the problem of photorespiration? (Exercise L-0.10)

i. C-4 Photosynthesis

- Some plants including grasses (corn, sugarcane and sorghum) and about two dozen other plant groups run a special pathway called C-4 photosynthesis in addition to the normal Calvin cycle. In their leaves, the mesophyll cells have less air spaces.
- The enzymes of Calvin cycle are more deposited in specialized cells called **bundlesheath cells**, which are impermeable to CO_2 .
- During C-4 photosynthesis (Fig) in mesophyll cells, CO_2 is attached with a 3-carbon molecule called phosphoenol pyruvic acid. It results in the formation of a four-carbon molecule oxaloacetic acid.
- Due to this first 4-C product, this process is called **C-4 photosynthesis** and the plants are called **C-4 plants**.

Check Understanding!

22. How do mitochondria contribute to photorespiration?

- Oxaloacetic acid is then converted to malic acid, by using NADH. Malic acid is transported to an adjacent bundle-sheath cell. Here, malic acid is broken down to pyruvic acid and CO₂.
- These cells can hold CO₂ in them. So, concentration of CO₂ increases in these cells and they run Calvin cycle instead of photorespiration.
- Pyruvic acid produced in bundle sheath cells returns to mesophyll cell and is converted again to phosphoenol pyruvic acid using an ATP.

- In C-4 photosynthesis, the energy cost for making a glucose molecule is almost double.
- However, in hot climates, in which photorespiration would otherwise remove more than half of the carbon fixed, it is best compromise available.

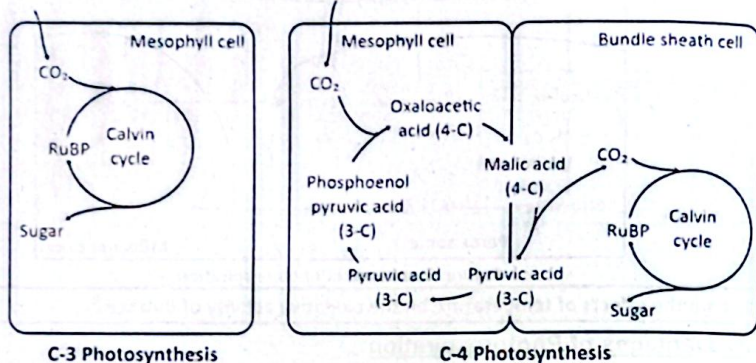
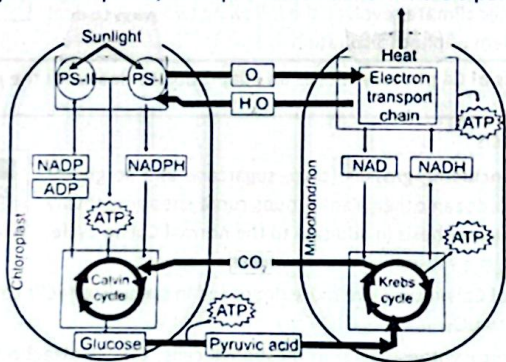

Figure: C-3 photosynthesis and C-4 photosynthesis

CAM Metabolism: (CAM: Crassulaceal Acid Metabolism)

- In hot climates, many succulent plants such as Cacti, pineapples and some other plant groups perform Crassulaceal acid metabolism or CAM (after the plant family Crassulaceae in which it was first discovered). In these plants, the stomata open during the night and close during the day.
- Closing stomata during the day prevents water loss and removal of CO₂. So, rate of photorespiration is reduced due to high concentration of carbon dioxide.
- The carbon dioxide necessary for producing sugar is provided from organic molecules made the night before.
- Use Both Pathways:** Like C-4 plants, these plants use both C-4 and C-3 pathways.

- From the given flowchart, build a paragraph that can describe a comparison between photosynthesis and respiration in terms of reactants and products of major steps.



Check Understanding (Solutions)

Sr. #	Option	Explanation
1.	C	The terminal phosphate bonds in ATP are unstable and release large amounts of energy when hydrolyzed.
2.	S.Q	Light initiates the light-dependent reactions in chloroplasts. It provides energy to split water (photolysis), releasing oxygen. It helps form ATP and NADPH, which fuel the Calvin cycle. Without light, photosynthesis cannot proceed effectively.
3.	C	Van Niel proposed that oxygen released in photosynthesis is derived from the splitting of water molecules, not from carbon dioxide.
4.	S.Q	Chlorophyll a is directly involved in the photochemical reactions at the reaction center. It absorbs light mainly in the red and blue-violet regions and converts it into chemical energy during photosynthesis.
5.	B	Both PSI and PSII contain a reaction center with chlorophyll a where excitation and electron transfer are initiated.
6.	S.Q	DNA-containing complexes encode some proteins for photosystems. These proteins form parts of reaction centers and antenna complexes. Their presence supports the semi-autonomous nature of chloroplasts.
7.	C	Electrons in non-cyclic photophosphorylation originate from water molecules during photolysis.
8.	S.Q	PSII contains P680 and splits water molecules (photolysis). PSI contains P700 and helps form NADPH. Both work together in the Z-scheme to drive photosynthesis.
9.	D	Photolysis of water, producing electrons, protons, and O ₂ , occurs exclusively in PSII.
10.	S.Q	Electrons flow through carriers, pumping H ⁺ into the thylakoid lumen. A proton gradient builds up across the thylakoid membrane. H ⁺ flows back into the stroma through ATP synthase. This flow powers the synthesis of ATP.
11.	C	The coupling factor (CF ₁ -CF ₀ complex) is the chloroplast equivalent of ATP synthase and catalyzes ATP formation.
12.	S.Q	First phase of the Calvin cycle. CO ₂ is captured and fixed by Rubisco enzyme. It reacts with RuBP (5-carbon) to form a 6-carbon unstable compound, which quickly splits into two 3-PGA molecules.
13.	C	The Calvin cycle is cyclical because RuBP is regenerated at the end to allow the cycle to repeat.
14.	S.Q	Occurs in the absence of oxygen. Involves incomplete breakdown of glucose. Produces less ATP compared to aerobic respiration. Results in end products like ethanol or lactic acid.
15.	D	The ETC produces the most ATP via oxidative phosphorylation.
16.	S.Q	NAD ⁺ is essential for glycolysis to continue. Fermentation regenerates NAD ⁺ from NADH. This ensures continuous ATP production in anaerobic conditions. Without NAD ⁺ , glycolysis would halt.
17.	B	Pyruvate is decarboxylated, releasing one molecule of CO ₂ per pyruvate during its conversion to acetyl-CoA.

18.	S.Q	<ul style="list-style-type: none"> It combines with acetyl-CoA to form citrate (6C). It is regenerated at the end of the cycle. Ensures the cycle can repeat continuously. Acts as a carrier of carbon atoms entering the cycle.
19.	A	<ul style="list-style-type: none"> Complex I (NADH dehydrogenase) receives electrons from NADH and pumps protons across the membrane.
20.	S.Q	<ul style="list-style-type: none"> Takes place in glycolysis and the Krebs cycle. Happens when high-energy intermediates donate phosphate groups to ADP. Does not occur in the electron transport chain stage.
21.	C	<ul style="list-style-type: none"> Peroxisomes contain enzymes that metabolize glycolate during photorespiration.
22.	S.Q	<ul style="list-style-type: none"> Convert glycine into serine. Release CO₂ during this conversion. Supply energy required for recycling metabolites.

Exercise

Exercise

MULTIPLE CHOICE QUESTIONS (MCQs)

Section 01

- What main process occurs during the dark reaction of photosynthesis?
 - Release of oxygen
 - Energy absorption by chlorophyll
 - Adding of hydrogen to CO₂
 - Formation of ATP
- What is TRUE about glycolysis?
 - It produces no ATP
 - It takes place only in aerobic respiration
 - It takes place in the mitochondrion
 - It reduces 2 molecules of NAD⁺ for every glucose molecule processed
- Which of the following are produced by the reactions that occur in the thylakoid and consumed by the reactions that occur in the stroma?
 - CO₂ and H₂O
 - Glucose and O₂
 - NADP⁺ and ADP
 - ATP and NADPH
- When deprived of oxygen, yeast cells obtain energy by fermentation, producing CO₂, ATP and;
 - Acetyl CoA
 - Ethyl alcohol
 - Lactic acid
 - Pyruvic acid
- Conversion of Glucose 6-phosphate into Fructose 6-phosphate is;
 - Isomerization
 - Polymerization
 - Condensation
 - Phosphorylation
- In which of the following conversions, ATP is produced?
 - Alpha ketoglutaric acid into succinyl CoA
 - Succinyl CoA into succinic acid
 - Succinic acid into fumaric acid
 - Fumaric acid into malic acid
- In electron transport chain, FADH:H produces how many ATPs?
 - One
 - Two
 - Three
 - Four
- Which of these is CO₂ acceptor during photosynthesis?
 - Malic acid
 - Ribulose biphosphate
 - Oxaloacetic acid
 - Phosphoglyceric acid
- Which of the following takes the electrons lost by Photosystem I on absorption of light energy?
 - Ferredoxin
 - Cytochrome
 - Cytochrome a³
 - Plastocyanin
- Photosystem-II makes up the electrons lost due to light excitation by taking up the electrons released from.
 - Ferredoxin
 - NADPH: H⁺
 - Plastocyanin
 - Photolysis of water

Answer Key with Explanations

Sr.No.	Option	Answer	Explanations
1.	(c)	Adding of hydrogen to CO ₂	The dark reaction (Calvin cycle) involves the fixation of CO ₂ into glucose using the energy from ATP and NADPH produced in the light-dependent reactions, effectively adding hydrogen to CO ₂ .
2.	(d)	It reduces 2 molecules of NAD ⁺ for every glucose molecule processed	Glycolysis results in the reduction of 2 NAD ⁺ molecules to NADH as it processes one glucose molecule into pyruvate.
3.	(d)	ATP and NADPH	The light-dependent reactions in the thylakoids produce ATP and NADPH, which are then consumed by the Calvin cycle (dark reactions) in the stroma.
4.	(b)	Ethyl alcohol	Yeast fermentation is alcoholic fermentation, producing ethanol (ethyl alcohol) and CO ₂ as byproducts.
5.	(a)	Isomerization	This conversion involves rearranging the molecular structure without adding or removing atoms, which is characteristic of isomerization.
6.	(a)	Alpha ketoglutaric acid into succinyl CoA	The conversion of alpha-ketoglutarate to succinyl-CoA is accompanied by the production of NADH and CO ₂ , and the subsequent conversion of succinyl-CoA to succinate produces GTP (or ATP in some contexts), but directly it's the step that involves the production of NADH. However, the most straightforward ATP production in the given options is not directly listed; the closest correct step related to the citric acid cycle and ATP production indirectly is through the conversion involving GTP.
7.	(b)	Two	FADH ₂ donates electrons to the electron transport chain at a later stage than NADH, resulting in the production of approximately 2 ATP molecules.
8.	(b)	Ribulose biphosphate	Ribulose-1,5-bisphosphate (RuBP) is the CO ₂ acceptor molecule in the Calvin cycle.
9.	(a)	Ferredoxin	Ferredoxin is the electron acceptor for Photosystem I, receiving the electrons excited by light energy.
10.	(d)	Photolysis of water	Photosystem II replenishes its lost electrons by taking electrons from the photolysis of water, splitting water into oxygen, protons, and electrons.

Exercise

SHORT ANSWER QUESTIONS

Section 02

Q.1 Differentiate between action spectrum and absorption spectrum.

Ans.	Action Spectrum	Absorption Spectrum
	<ul style="list-style-type: none"> Action Spectrum: Shows the effectiveness of different wavelengths in driving photosynthesis. Action spectrum is determined by measuring oxygen production or CO₂ uptake. 	<ul style="list-style-type: none"> Absorption Spectrum: Shows the wavelengths of light absorbed by pigments. Absorption is measured using a spectrophotometer.

Photosynthesis a redox reaction?**Photosynthesis as Redox Reaction:**

- Photosynthesis is a redox (reduction-oxidation) reaction.
 - Water is oxidized to release oxygen (loss of electrons).
 - Carbon dioxide is reduced to form glucose (gain of electrons).
 - Electrons are transferred from water to CO₂ via electron carriers.
- This electron flow forms the basis of the redox nature of photosynthesis.

Which molecule contributes Oxygen in glucose? Water or carbon dioxide!**Q.2: Contributes Oxygen in Glucose:**

- The oxygen in glucose (C₆H₁₂O₆) comes from carbon dioxide (CO₂).
- During the Calvin cycle, CO₂ is fixed and incorporated into sugar.
- Water contributes the oxygen that is released as O₂ gas.
- So, CO₂ is the carbon and oxygen source for glucose molecules.

State the role of CO₂ in photosynthesis.**Role of CO₂ in Photosynthesis:**

- CO₂ is the raw material used in the Calvin cycle of photosynthesis.
- It is fixed by the enzyme RuBisCO to produce glucose.
- Each CO₂ molecule contributes one carbon atom to the sugar.
- Without CO₂, no carbohydrate formation can occur.
- It is the carbon source for building plant biomass.

Q.5 Define electron transport chain.**Ans. Electron Transport Chain:**

- The ETC is a series of protein complexes located in membranes (thylakoid or mitochondria).
- Electrons pass through these complexes and release energy.
- This energy is used to pump protons and create a proton gradient.
- In chloroplasts, it leads to ATP and NADPH formation (photophosphorylation).
- In mitochondria, it results in ATP production via oxidative phosphorylation.

Q.6 What do you mean by glycolysis?**Ans. Glycolysis:**

- Glycolysis is the first step of cellular respiration, occurring in the cytoplasm.
- It breaks down one glucose molecule into two pyruvic acid molecules.
- Net gain of 2 ATP and 2 NADH molecules occurs.
- It does not require oxygen (anaerobic).
- It prepares glucose for further breakdown in mitochondria.

Q.7 What is the main structural difference between chlorophyll-a and chlorophyll-b?

Chlorophyll 'a'	Chlorophyll 'b'
<ul style="list-style-type: none"> Chlorophyll a has methyl group (-CH₃) Molecular formulae is C₅₅H₇₂O₅N₄Mg It is blue-green (BG) in colour. It takes part directly in the light-dependent reaction which converts solar energy to chemical energy. It is found in all photosynthetic organisms except photosynthetic bacteria. Chlorophyll a itself exists in several forms differing slightly in their red absorbing peak e.g. 670, 680, 690 700 nm. 	<ul style="list-style-type: none"> Chlorophyll b has carbonyl group (-CHO). Molecular formula is C₅₅H₇₀O₆N₄Mg It is yellow-green in colours (YG) Chlorophyll b is found along with chlorophyll a in all green plant and green algae. It does not directly involve in photosynthesis.

Q.8 How can a cell synthesize ATP through substrate-level phosphorylation?**Ans. Synthesize ATP through Substrate-level Phosphorylation:**

- ATP is formed by the direct transfer of a phosphate group to ADP from a phosphorylated substrate.
- This occurs during glycolysis and the Krebs cycle.
- It does not require oxygen or electron transport chain.
- It is different from oxidative phosphorylation, which involves membranes.
- Example: Conversion of phosphoenolpyruvate to pyruvate by pyruvate kinase.

Q.9 Can pyruvic acid enter Krebs cycle as such? If not, what changes are made to it before Krebs cycle?**Ans. Entrance of Pyruvic Acid in to Krebs Cycle:**

- No, pyruvic acid cannot directly enter the Krebs cycle.
- It must be converted into acetyl-CoA by oxidative decarboxylation.
- This process releases CO₂ and produces NADH.
- The enzyme involved is the pyruvate dehydrogenase complex.
- Acetyl-CoA then enters the Krebs cycle.

Q.10 Differentiate between C-3 and C-4 photosynthesis.

C ₃ Plants	C ₄ Plants
<ul style="list-style-type: none"> First stable product is a 3-carbon compound (3-PGA). Occurs in mesophyll cells. Less efficient in hot, dry conditions. 	<ul style="list-style-type: none"> First product is a 4-carbon compound (oxaloacetate). CO₂ fixation occurs in mesophyll, Calvin cycle in bundle sheath cells. More efficient in high light and temperature.

Exercise**LONG ANSWER QUESTIONS****Section 03**

- What are photosynthetic pigments and what role they play in the absorption and conversion of light energy?
Ans. See Page No. (185)
- How are the absorption spectra of chlorophyll 'a' and 'b' different?
Ans. See Page No. (186)
- Describe and illustrate how photosynthetic pigments are organized in thylakoid membrane?
Ans. See Page No. (186)
- Describe how the role of water in photosynthesis can be explained through experiment.
Ans. See Page No. (184)
- What are the events that capture light and convert it into chemical energy during light dependent reactions?
Ans. See Page No. (188)
- Illustrate the cyclic photophosphorylation.
Ans. See Page No. (190)
- Describe light independent reactions of photosynthesis in terms of paragraph and illustrate in terms of Calvin cycle.
Ans. See Page No. (191)
- What happens with glucose in anaerobic respiration and how different organisms modify the end products?
Ans. See Page No. (193)
- How is glucose broken down to pyruvic acid in glycolysis?
Ans. See Page No. (195)
- Describe how Krebs cycle is the completion of the oxidation of glycolytic products.
Ans. See Page No. (196)

Q.11 Explain the passage of electron through electron transport chain.

Ans. See Page No. (197)

Q.12 Define chemiosmosis. How would you relate it with electron transport chain?

Ans. See Page No. (197)

Q.13 Through which ways proteins and fats enter cellular respiration?

Ans. See Page No. (200)

Q.14 Define photorespiration and present it in proving that "photosynthesis is not perfect".

Ans. See Page No. (200)

Q.15 What are the effects of temperature on the oxidative activity of Rubisco?

Ans. See Page No. (201)

Q.16 How is the process of C₄ photosynthesis an adaptation to deal with the problem of photorespiration?

Ans. See Page No. (201)

Exercise

INQUISITIVE ANSWER QUESTIONS

Q.1 Why does cellular respiration release energy more efficiently than fermentation?

- Ans.
- Cellular respiration completely breaks down glucose into carbon dioxide and water, while fermentation only partially breaks down glucose into substances like lactic acid or ethanol.
 - Cellular respiration produces about 36 ATP molecules per glucose, which is much higher than fermentation's 2 ATP molecules per glucose.
 - Cellular respiration uses oxygen as the final electron acceptor, allowing efficient energy extraction through the electron transport chain.
 - Fermentation uses organic molecules as electron acceptors and does not involve the electron transport chain, resulting in less efficient energy release.

Q.2 Why is the conversion of glucose into ATP during cellular respiration considered a more efficient use of energy than burning glucose directly?

Ans. Burning Glucose Directly:

- Energy is released all at once as heat.
- Most of this energy is lost and cannot be stored or used by the cell.

Conversion of Glucose into ATP:

- Energy is released gradually in controlled steps.
- Energy is captured and stored in ATP molecules, which cells use efficiently for various functions.

Q.3 Why might a disruption in either photosynthesis or respiration processes affect global carbon and oxygen cycles?

Ans. Disruption in Photosynthesis:

- Carbon Imbalance:** Photosynthesis removes carbon dioxide from the atmosphere; disruption would lead to increased CO₂ levels, contributing to global warming.
- Reduced Oxygen Production:** Less oxygen would be released, affecting organisms that depend on it for respiration.
- Energy Flow Impact:** Plants are primary producers; if they produce less glucose, energy availability for herbivores and higher trophic levels decreases.

Disruption in Respiration:

- Slowed Carbon Return:** Respiration releases CO₂ back into the atmosphere; without it, the carbon cycle would be incomplete and imbalanced.
- Energy Deficiency in Cells:** Cells would be unable to produce sufficient ATP, disrupting all energy-dependent life processes.
- Waste Buildup:** Without proper respiration, harmful byproducts like pyruvate or lactic acid would accumulate in organisms.

ADDITIONAL MCQs

- Q.1 During photosynthesis, the oxygen released originates specifically from:
 A) Carbon dioxide reduction
 B) Photolysis of water at PSII
 C) Photorespiration in mitochondria
 D) Conversion of NADP⁺ to NADPH
- Q.2 The accessory pigments in plants mainly serve to:
 A) Replace chlorophyll in case of deficiency
 B) Widen the range of absorbed light wavelengths
 C) Produce ATP in mitochondria
 D) Initiate the Calvin cycle
- Q.3 What property of chlorophyll molecules makes them suitable for converting light energy?
 A) Their hydrophilic tail regions
 B) Their nonpolar nature
 C) Delocalized electrons in porphyrin ring
 D) Their reaction with rubisco
- Q.4 Which factor most contributes to the difference in absorption spectra of chlorophyll 'a' and 'b'?
 A) Difference in their ring structure
 B) Replacement of a methyl group with a formyl group
 C) Binding to different proteins
 D) Magnesium being absent in chlorophyll b
- Q.5 In chlorophyll structure, the phytol tail:
 A) Anchors it into the thylakoid membrane
 B) Absorbs green light
 C) Stores ATP
 D) Binds to water molecules
- Q.6 Which is true about the arrangement of pigments in Photosystem I?
 A) Antenna complex surrounds the P680 reaction center
 B) All pigments directly transfer electrons to NADP⁺
 C) Light-harvesting complexes funnel energy to P700
 D) Photosystem I contains only carotenoids
- Q.7 A major functional difference between cyclic and non-cyclic photophosphorylation is that:
 A) Only cyclic produces NADPH
 B) Only non-cyclic replenishes lost electrons via water splitting
 C) Only cyclic produces oxygen
 D) Only non-cyclic uses Photosystem I
- Q.8 The Z-scheme resembles the letter "Z" due to:
 A) The cyclic electron flow between PSI and PSII
 B) The energy levels of electrons as they move through the chain
 C) The actual shape of the chloroplast
 D) Proton accumulation in the stroma
- Q.9 Which enzyme catalyzes the carboxylation of RuBP in the Calvin cycle?
 A) ATP synthase
 B) Rubisco
 C) NADP⁺ reductase
 D) Phosphoglycerate kinase
- Q.10 Which of the following correctly describes the sequence of events in light reactions?
 A) NADPH formation → ATP synthesis → Photolysis
 B) Photolysis → Electron excitation → ATP/NADPH production
 C) ATP synthesis → Electron transport → Photolysis
 D) Calvin cycle → Electron transport → Light absorption
- Q.11 ATP is preferred as the cell's energy currency because:
 A) Its hydrolysis is endergonic and slow
 B) It forms glucose quickly
 C) It couples exergonic and endergonic reactions efficiently
 D) It can be stored long-term in vesicles

Q.12 ATP synthesis during cellular respiration occurs through:

- A) Passive transport
B) Diffusion of water
C) Substrate-level and oxidative phosphorylation
D) Active transport of glucose

Q.13 Which of the following correctly orders the four main stages of aerobic respiration?

- A) Glycolysis → Link reaction → Krebs cycle → ETC
B) Calvin cycle → Link reaction → Krebs cycle → ETC
C) Krebs cycle → Glycolysis → Calvin cycle → ETC
D) Glycolysis → ETC → Krebs cycle → Fermentation

Q.14 In yeast cells, anaerobic respiration results in:

- A) ATP, lactic acid, CO₂
B) Ethanol, CO₂, minimal ATP
C) Pyruvate and oxygen
D) Acetyl-CoA and FADH₂

Q.15 The net ATP gain from glycolysis is:

- A) 0
B) 2
C) 4
D) 36

Q.16 The conversion of pyruvate to acetyl-CoA involves:

- A) Oxidative phosphorylation
B) Substrate-level phosphorylation
C) Decarboxylation and CoA binding
D) Hydrolysis of water

Q.17 Which combination is a direct product of one turn of the Krebs cycle?

- A) 2 ATP, 2 CO₂, 6 NADH
B) 3 NADH, 1 FADH₂, 1 GTP
C) Glucose and oxygen
D) NADH and glucose

Q.18 The reduced forms NADH and FADH₂ serve primarily to:

- A) Provide oxygen to the mitochondria
B) Donate electrons to ETC for ATP generation
C) Store ATP
D) Initiate glycolysis

Q.19 Which best describes the redox activity in ETC?

- A) ATP is oxidized
B) Electrons are reduced as they flow
C) Each electron carrier is alternately reduced and oxidized
D) Oxygen is oxidized to water

Q.20 The immediate energy source for ATP synthesis in chemiosmosis is:

- A) Glucose oxidation
B) NADPH breakdown
C) Proton gradient across inner mitochondrial membrane
D) Light energy

Q.21 Why is ATP yield significantly higher in aerobic respiration than anaerobic?

- A) Glycolysis is bypassed
B) More NADH is used
C) Oxygen allows complete oxidation of glucose via ETC
D) Pyruvate remains unconverted

ANSWER KEY

1. B)	2. B)	3. C)	4. B)	5. A)	6. C)	7. B)	8. B)	9. B)	10. B)	11. C)	12. C)
13. A)	14. B)	15. B)	16. C)	17. B)	18. B)	19. C)	20. C)	21. C)			

ADDITIONAL SHORT ANSWER QUESTIONS

1. Define Bioenergetics.

Ans. Bioenergetics:

- Bioenergetics is the quantitative study of energy relationships and energy conversion in biological systems.
- Yes, biological energy transformations obey the laws of thermodynamics.
- All organisms need free energy for keeping themselves alive and functioning.

2. What is compensation point? Give its timings.

Ans. Compensation Point:

- At Dawn and Dusk when light intensity is low, the rate of photosynthesis and respiration may, for a short time becomes equal to one another at this point the oxygen released from photosynthesis is just equals to the amount required for cellular respiration.
- Also the carbon dioxide released by respiration just equals the quantity required by photosynthesizing cells. Thus at this time there is no net gas exchange occurs between the leaves and the atmosphere is termed as compensation point.

3. How it was proved that oxygen released during photosynthesis comes from water and not from CO₂?

Ans. O₂ Released During Photosynthesis Comes From Water:

- Neil's hypothesis that source of oxygen released during photosynthesis is water and not carbon dioxide, was later confirmed by scientists during 1940s, when first use of an Isotopic tracer (O¹⁸) in biological research was made.
- Experimental green plants in one group were supplied with H₂O containing O¹⁸ and with CO₂ containing only common oxygen O¹⁶.
- Plants in the second were supplied with H₂O containing common oxygen O¹⁶ but with CO₂ containing O¹⁸.
- It was found that plants of first group produced O¹⁸ but the plants of second group produced O¹⁶.

Group -1 Plants:

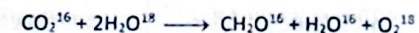

Group - 2 Plants:

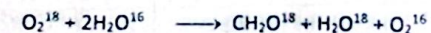

- Result: So proved that during light reactions of photosynthesis, oxygen (O₂) comes from water not from CO₂.

4. What is a porphyrin ring of a chlorophyll molecule?

Ans. Porphyrin Ring of a Chlorophyll Molecule:

- It is flat and square.
- Light absorbing and hydrophilic part.
- It is made up of 4 joined smaller pyrole rings composed of carbon and nitrogen atom.
- An atom of magnesium is present in the center of porphyrine ring and is attached with the nitrogen of each pyrole ring. That's why magnesium deficiency causes yellowing in plants.
- Haeme portion of haemoglobin has also a porphyrin ring but containing an iron atom instead of magnesium atom in the center.

5. What are accessory pigments? Give two examples.

Ans. Accessory Pigments:

- The pigments which are not directly involved in photosynthesis instead of that they transfer energy to chlorophyll a for reactions of photosynthesis. e.g., carotenoids, chl b.
- Carotenoids and chlorophyll b are called accessory pigments because they absorb light and transfer the energy to chlorophyll a, which then initiates the light reactions.

- Carotenoids are yellow and red to orange pigments and absorb strongly the blue violet range, different wave lengths than the chlorophyll absorbs.
- It is generally believed that the order of transfer of energy is:

Carotenoids → Chlorophyll b → Chlorophyll a

6. Differentiate between Absorption spectrum and Action spectrum.

Ans.	Action Spectrum	Absorption Spectrum
	<ul style="list-style-type: none"> • A graph showing relative effectiveness of different wave lengths of light color on the rate of photosynthesis is called action spectrum. • Different wave lengths are not only absorbed by photosynthetic pigments but are also have different effects in photosynthesis. 	<ul style="list-style-type: none"> • A graph showing the relative absorption of different wavelength of light by different pigments is called absorption spectrum. • In which for chlorophylls indicates that absorption maximum in blue and red parts of the spectrum two absorption peaks being at around 430nm and 670nm respectively. Absorption peaks of carotenoids are different from those of chlorophyll.

7. What is the role of antenna complex in photosynthesis?

Ans. Role of Antenna Complex In Photosynthesis:

- Antenna complex is the part of photosystem and is light gathering part.
- Antenna complex is composed of:
 - (i) Chlorophyll a
 - (ii) Chlorophyll b
 - (iii) Carotenoids
- Which are responsible for channeling the energy to reaction center.

8. Differentiate between photosystem I and photosystem II.

Ans.	Photosystem I	Photosystem II
	<ul style="list-style-type: none"> • Photo system I has chlorophyll a molecule which absorb maximum light of 700 nm is called P₇₀₀. • Photo system I is involved in both non-cyclic and cyclic phosphorylation. 	<ul style="list-style-type: none"> • Photo system II Has chlorophyll a molecule which absorbs maximum light of 680 nm is called P₆₈₀. • Photo system II is involved only in non-cyclic phosphorylation.

9. What is chemiosmosis?

Ans. Chemiosmosis:

- The process in which hydrogen ions move down their gradient through special complexes called ATP synthases which is present in the thylakoid membrane. During this diffusion of hydrogen ion, the energy of electrons is used to make ATP, this process is called chemiosmosis.
- Electron transport chain pumps protons (H⁺) across the membrane into thylakoids space. The energy used for the pumping comes from the electrons moving through the electron transport chain. This energy is transformed into potential energy stores in the membrane and then used during dark reactions.

10. Define photophosphorylation. Give its types.

Ans. Photophosphorylation:

- As electrons move down the chain, their energy goes on decreasing and is used by ATP – Synthase of thylakoid membrane to produce ATP. The ATP synthesis in the presence of light is called photophosphorylation.
- ATP generated by the light reactions will provide chemical energy for the synthesis of sugar during the Calvin cycle.

11. Differentiate between Light Reactions and Dark Reactions of Photosynthesis.

Ans.	Light Dependent Reactions (Oxidation Phase, Photolysis)	Light Independent Reactions (Dark Reactions)
	<ul style="list-style-type: none"> • Phase during which light energy is absorbed by chlorophyll and other photosynthetic pigments. • It is then converted into chemical energy. Due to this energy conversions, reducing and assimilating power in the form of NADPH₂ (NADPH·H) and ATP are produced, both are used in the light independent reactions. • Products of Light Reactions: <ul style="list-style-type: none"> • ATP, NADPH and Oxygen. 	<ul style="list-style-type: none"> • This phase is also called dark reactions because these reactions do not use light directly and can take equally well both in light and dark provided NADPH₂ and ATP of light reactions are available. • NADPH₂ provides energized electron and H⁺ ions during dark reactions. • ATP provides chemical energy. • CO₂ uses reducing power and chemical energy of NADPH₂ and ATP respectively. • The energy is thus stored in the molecules of sugar.

12. How anaerobic respiration is important?

Ans. Importance of Anaerobic Respiration:

- During anaerobic respiration only about 2% of the energy present with in the chemical bonds of glucose is converted into adenosine triphosphate.
- Two ATP produced per glucose during fermentation is equivalent to 14.6 Kcal. But fermentation is a way to produce ATP even through O₂ is temporarily in limited supply.
- The commercial use of anaerobic respiration include the production of biogas, butter from milk, yogurt, and cheese.
- It is also used in wine-making, baking and brewing industries.

13. Differentiate between aerobic and anaerobic respiration.

Ans.	Aerobic Respiration	Anaerobic Respiration
	<ul style="list-style-type: none"> • Aerobic respiration occurs in the presence of free molecular O₂. • Produce a lot of ATP per glucose molecule. 	<ul style="list-style-type: none"> • Anaerobic respiration occurs in the absence of free O₂. • Produce less ATP per glucose molecule.

14. How do CAM plants adapt to arid environments through their metabolism?

- ##### Ans.
- CAM plants open stomata at night to fix CO₂, minimizing water loss.
 - CO₂ is stored as malic acid in vacuoles.
 - During the day, stomata close, and CO₂ is released internally for photosynthesis.
 - This temporal separation conserves water efficiently.

15. Describe the phases of CAM metabolism in brief.

- ##### Ans.
- **Night phase:** Stomata open; CO₂ fixed into oxaloacetate, converted to malic acid, and stored.
 - **Day phase:** Stomata close; malic acid decarboxylated to release CO₂.
 - Released CO₂ enters Calvin cycle for carbohydrate synthesis.
 - This process reduces water loss and photorespiration.



SELF-ASSESSMENT Chapter # 06

Total Mark: 30

(1 x 6 = 06)

Q.1 Encircle the correct option.

- i. The accessory pigments in plants mainly serve to:

(a) Replace chlorophyll in case of deficiency	(b) Widen the range of absorbed light wavelengths
(c) Produce ATP in mitochondria	(d) Initiate the Calvin cycle
- ii. In chlorophyll structure, the phytol tail:

(a) Anchors it into the thylakoid membrane	(b) Absorbs green light
(c) Stores ATP	(d) Binds to water molecules
- iii. Which enzyme catalyzes the carboxylation of RuBP in the Calvin cycle?

(a) ATP synthase	(b) Rubisco	(c) NADP+ reductase	(d) Phosphoglycerate kinase
------------------	-------------	---------------------	-----------------------------
- iv. The net ATP gain from glycolysis is:

(a) 0	(b) 2	(c) 4	(d) 36
-------	-------	-------	--------
- v. When deprived of oxygen, yeast cells obtain energy by fermentation, producing CO₂, ATP and;

(a) Acetyl CoA	(b) Ethyl alcohol	(c) Lactic acid	(d) Pyruvic acid
----------------	-------------------	-----------------	------------------
- vi. In electron transport chain, FADH₂ produces how many ATPs?

(a) One	(b) Two	(c) Three	(d) Four
---------	---------	-----------	----------

Q.2 Write short answers of the following questions.

(2 x 8 = 16)

- i. How does the energy from ATP and NADPH contribute to the reduction phase of the Calvin cycle?
- ii. What is the relationship between the Calvin cycle and glycolysis, as indicated by the mention of G3P?
- iii. Which molecule contributes Oxygen in glucose? Water or carbon dioxide?
- iv. Define electron transport chain.
- v. What is the main structural difference between chlorophyll-a and chlorophyll-b?
- vi. Can pyruvic acid enter Krebs cycle as such? If not, what changes are made to it before Krebs cycle?
- vii. Define photophosphorylation. Give its types.
- viii. Describe the phases of CAM metabolism in brief.

Q.3 Extensive Questions.

(4 x 2 = 8)

- (a) What are photosynthetic pigments and what role they play in the absorption and conversion of light energy?
- (b) How is glucose broken down to pyruvic acid in glycolysis?

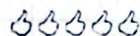

ENTRANCE TEST

MCQs (UHS)

1. In light independent stage of photosynthesis the CO₂ combines with _____ to form an unstable 6-carbon intermediate.

A. Ribulose biphosphate	B. Glycerate-3-phosphate
C. Hexose sugar	D. Glyceraldehyde-9-phosphate
2. In glycolysis, glycerate 1,3-bisphosphate is converted into glycerate-3-phosphate by losing _____ phosphate molecules.

A. 3	B. 1	C. 2	D. 4
------	------	------	------
3. Malate is oxidized by _____ to oxaloacetate in Krebs Cycle.

A. ATP	B. NAD	C. NADP	D. FAD
--------	--------	---------	--------
4. In electron transport chain, the electrons from NADH and FADH₂ are passed to:

A. Cytochrome a	B. Co-enzyme c	C. Cytochrome a ₃	D. Co-enzyme Q
-----------------	----------------	------------------------------	----------------
5. Carriers of the respiratory chain are located on:

A. Matrix of mitochondria	B. Inner membrane of mitochondria
C. Outer membrane of mitochondria	D. Cytoplasmic matrix
6. Each _____ consists of a light gathering antenna complex and reaction center.

A. Chlorophyll	B. Photon	C. Photosystem	D. Electron
----------------	-----------	----------------	-------------
7. Photosystem 'I' has chlorophyll 'a' molecules which absorb maximum light of:

A. 680 nm	B. 700 nm	C. 780 nm	D. 580 nm
-----------	-----------	-----------	-----------
8. Cyclic flow or C4 photosynthesis produces:

A. ATP and CO ₂	B. Only CO ₂	C. ATP	D. Only oxygen
----------------------------	-------------------------	--------	----------------
9. Immediate product formed after CO₂ fixation in Calvin cycle is:

A. Unstable 6-carbon compound	C. Unstable 4-carbon compound
C. Unstable 5-carbon compound	D. Unstable 3-carbon compound
10. Functional group of chlorophyll 'a' is:

A. -CH ₃	B. -COOH	C. -CHO	D. -OH
---------------------	----------	---------	--------
11. Chlorophyll molecules contains:

A. Mg ⁺⁺	B. K ⁺	C. Ca ⁺⁺	D. Na ⁺
---------------------	-------------------	---------------------	--------------------
12. The tail of chlorophyll molecule is embedded in:

A. Membrane of mitochondria	B. Thylakoid membrane
C. Membrane of smooth endoplasmic reticulum	D. Membrane of rough endoplasmic reticulum
13. Carotenoids absorb light of:

A. Yellow-orange range	B. Orange-red range	C. Yellow-red range	D. Blue-violet range
------------------------	---------------------	---------------------	----------------------
14. Chlorophyll a and chlorophyll b differ from each other in only one of the functional groups; chlorophyll a has:

A. -CHO	B. -CH ₂	C. -OH	D. -NH ₂
---------	---------------------	--------	---------------------
15. Glycerate 3-phosphate in the presence of ATP and reduced NADP from light dependent stage is reduced to:

A. 3 Carbon compound	B. 5 Carbon compound
C. Ribulose bisphosphate	D. 6 Carbon compound
16. Calvin cycle occurs in:

A. Grans of chloroplast	D. Chlorophyll (reaction center)
C. Stroma of chloroplast	D. Roots of plants
17. _____ is the site of light independent reaction:

A. Thylakoid membrane	B. Stroma	C. Thylakoid space	D. Grana
-----------------------	-----------	--------------------	----------
18. The enzymes required in glycolysis are present in:

A. Golgi apparatus	B. Inner mitochondrial membrane
C. Cell cytoplasm	D. Matrix of mitochondria
19. At the last step of glycolysis which of the following compound is formed:

A. Pyruvic acid	B. Ethyl alcohol	C. Lactic acid	D. Fructose phosphate
-----------------	------------------	----------------	-----------------------
20. NADP, nicotinamide adenine dinucleotide phosphate, is a carrier of:

A. -OH group	B. Hydrogen	C. O ₂ group	D. Phosphate
--------------	-------------	-------------------------	--------------